



GENUINE SIDE AIR DAM SKIRT

INSTALLATION INSTRUCTIONS

Thank you for purchasing a genuine Mazda accessory.
Before removal and installation, be sure to thoroughly read these instructions.
Please read the contents of this booklet in order to properly install and use the side air dam skirt. Your safety depends on it.
Keep these instructions with your vehicle records for future reference.

WARNING

- There are several  **WARNING** and  **CAUTION** sections in this booklet concerning safety when installing or removing the side air dam skirt. Always read and follow them in order to prevent injuries, accidents, and possible damage to the vehicle.

 **WARNING:** Indicates a situation in which serious injury or death could result if the warning is ignored.

 **CAUTION:** Indicates a situation in which bodily injury or damage to the vehicle could result if the caution is ignored.

- Do not modify the side air dam skirt.
- Do not install the side air dam skirt in any way other than described in the following instructions.
- If in any doubt, please ask your Mazda dealer to install the accessory in order to prevent errors in installation.
- If you have any questions about the use of the accessory, ask your Mazda dealer for proper advice before using it.
- Mazda and its suppliers are not responsible for injuries, accidents, and damage to persons and property that arise from the failure of the dealer or installer to follow these instructions.
- To ensure safety and reliability of the work, installation, removal and disposal work must be carried out by an Authorized Mazda Dealership.
- Be careful not to lose removed parts, and be sure that they are kept free from scratches, grease or other dirt.

PART NAME: SIDE AIR DAM SKIRT

**PART NUMBER: NH52 V4 910
0000 8Y D03**

VEHICLE: MX-5

Note

To the dealer

- Please turn over these instructions to the customer after installation.

To the customer

- Keep these instructions after installation. The instructions may be necessary for installing other optional parts or removal of this accessory.
- Should the vehicle or this accessory be resold, always leave these instructions with it for the next owner.

1. PARTS

Parts list

NOTE

- Before installation, verify that the kit includes all the following parts and that they are free of dirt, scratches, or damage.

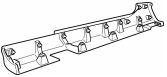
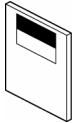
Part	Part name	Qty	Part	Part name	Qty
	Side air dam skirt	1ea.		Installation instructions	1

Installation view

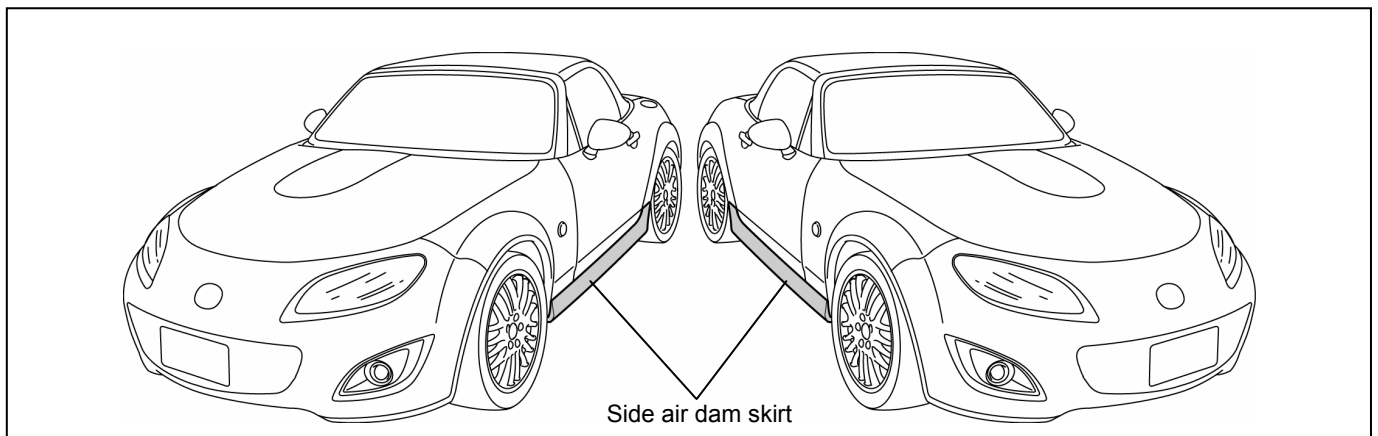

2. REQUIRED TOOLS

- ☆Screwdriver (Phillips)
- ☆Flathead screwdriver wrapped with Protective tape
- ☆Soft, clean cloth
- ☆Fastener remover

3. BEFORE INSTALLATION

⚠ CAUTION

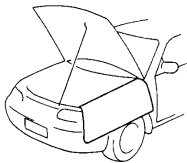
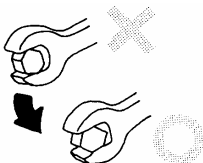
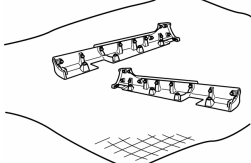
Be sure to cover the vehicle body with protectors or mats to prevent stains, scratches and damage when removing/installing the vehicle parts	Use the most appropriate (size, use) tool for each task and perform the may be damaged.	Place the removed parts and kit accessories on a protective sheet to prevent scratches.
		

NOTE

- Refer to the Workshop Manual for removal and installation of vehicle parts. Not following the procedures for removal/installation in the Workshop Manual could result in an accident or vehicle malfunction.

4. PART REMOVAL

⚠ WARNING

- Park the vehicle on a flat, level surface, set the selector lever to P (AT vehicles) or the shift lever to 1st or R (MT vehicles), apply the parking brake and block the wheels so that the vehicle does not move during

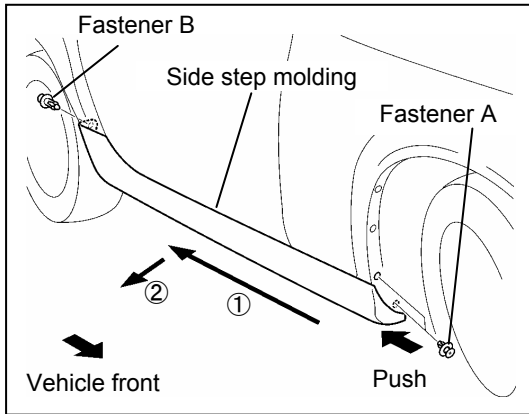

NOTE

- The figure shows the right side, however, perform the same procedure for the left side.

Side step molding (Accessory) removal

1. Turn the steering wheel fully to the right.
2. Remove the two fasteners A and the fastener B that are secured to the side step molding.
3. Push the front side of the side step molding rearward and remove it from the fasteners as indicated by the arrows (① ②).
4. Remove the side step molding clips (small) (10) remaining on the vehicle using the fastener remover.
5. Remove the side step molding clips (large) (5) remaining on the vehicle using a flathead screwdriver.

⚠ CAUTION

- When removing the clips, reshape the clips mounting holes if they become bent.

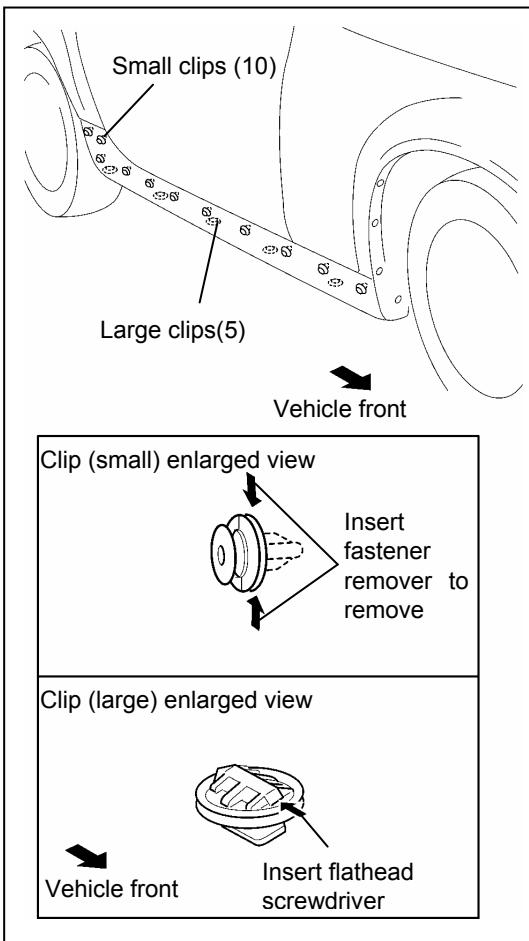

5. SIDE AIR DAM SKIRT INSTALLATION

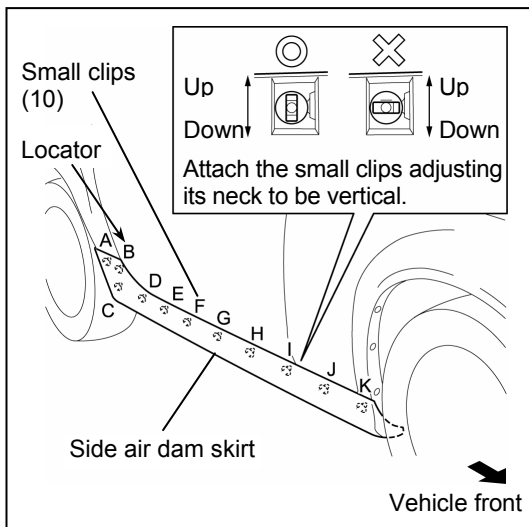

NOTE

- The figure shows the right side, however, perform the same procedure for the left side.

- To prevent false locking, adjust the ten small clips of the side air dam skirt (R.H.) so that they are sideways. (Refer to the diagram at left.)
- Gently push the ten clips into the vehicle mounting holes, starting with B and going from B to A, B to K.

CAUTION

- Insert the side air dam skirt at the front of the vehicle in between the vehicle body and the mudguard and then attach the small clips

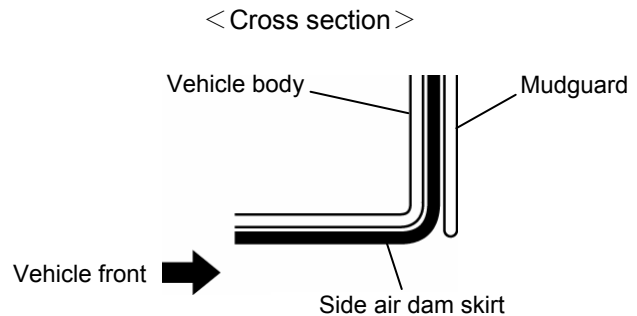

- Tighten the clips (large) on the underside of the vehicle to the vehicle installation holes.
- Install the two fasteners A and the fastener B that were removed from the side step moulding in step 1. of "4. PART REMOVAL" in reverse.

**INSTALLATION
INSPECTION
SHEET**

MX-5	SIDE AIR DAM SKIRT
	NH52 V4 910 0000 8Y D03

Inspection items after installation

- Inspect the installed/reinstalled parts for the following items:

Part	Check Item (○)		
	Clearance/Fit	Scratches/Dirt	Installation/ Engagement
Side air dam skirt	○	○	○

Installation inspection sheet for side air dam skirt

Date _____, _____, _____					
VIN. _____					
Approved		Checked		Person in charge	

The term of validity for this sheet: 12 months