

GENUINE SIDE AIR DAM SKIRT

Using Instructions

Applicable model: MX-5

Part Number : NF51 V4 910F

Thank you very much for buying the Mazda Genuine Parts.

Before removal and installation, you are expected to carefully read these instructions.

To use it in its best conditions, be sure to read thoroughly read these instructions for full Understanding of the contents and to properly use it.

< Cautions and Requests >

- ⚠ CAUTION and ⚠ WARNING marks shown in these instructions indicate safely precautions, which you are requested to strictly comply with during installation and use.

⚠ WARNING : Indicates a situation in which serious injury or death could result if the warning is ignored.

⚠ CAUTION : Indicates a situation in which bodily injury or damage to the vehicle could result in if the caution is ignored.

- Do not install the side air dam skirt in any way other than described in the following instructions.
- Do not modify the rear under spoiler.
- To ensure safety and reliability of the work, installation, removal and disposal work must be carried out by an authorized Mazda Dealership.
- If you have any questions about the use of the accessory, ask your Mazda dealer for proper advice before using it.
- We may not accept the liability for any problems that might have occurred due to incompliance with these instructions.
- Be careful not to lose removed parts, and be sure they are kept free from scratches, grease or other dirt.

To the dealer

Please turn over these instructions to the customer after installation.

To the customer

- Keep these instructions after installation. The instructions may be necessary for installing other optional parts or removal of this accessory.
- Should the vehicle or this accessory be resold, always leave these instructions with it for the next owner.

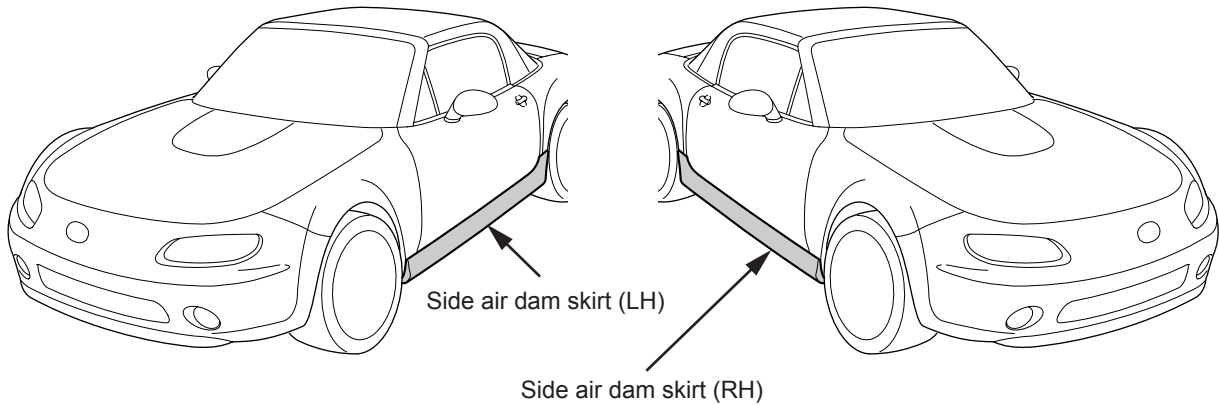

1

AS-COMPLETED VIEW

2

COMPONENTS**CAUTION**

Make sure that there is no missing component based on the following parts list and check the components for any dirt, scratches or other damage.

No.	Part name	Q'ty	Part number
①	Side air dam skirt (RH/LH)	Each 1	_____
②	Clip	2	NE55 51 SJ3
③	Clip	8	NE56 51 SJ3
④	Using instructions	1	_____

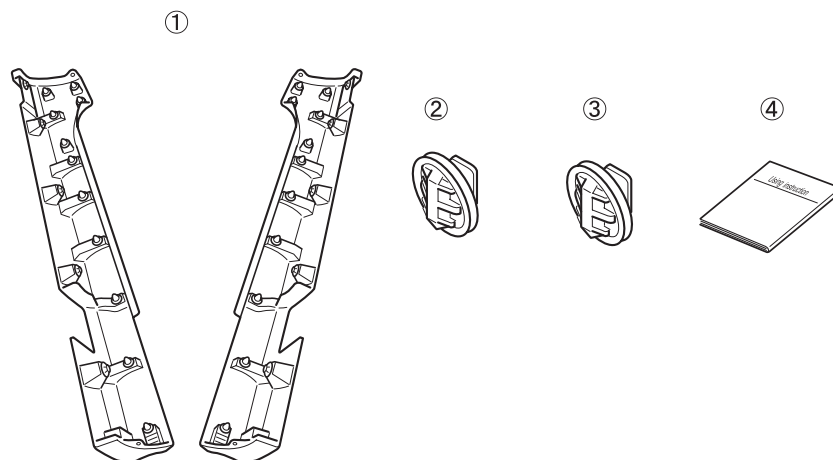

GENUINE SIDE AIR DAM SKIRT

Installation manual (supplemental version)

Applicable model: MX-5

Part Number : NF51 V4 910F

NE85 V4 910F

Make sure to read first

1 PREPARATORY WORK BEFORE INSTALLATION

Tools used (Have them ready at hand before starting the work)

- Squeegee
- Clean cloth
- Solvent or thinner
- Paper tape
- Marking pin
- Atomizer
- Neutral detergent
- Drier

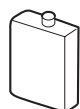

((White gasoline or alcohol))

(Dilute the concentrate solution by 1%)

2 PREPARATION OF VEHICLE

Clean off the dirt in the installation surface with clean cloth and then wipe off the oil and grease with clean cloth that is filled with white gasoline or alcohol.

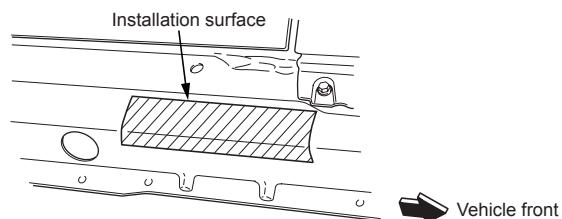

3 INSTALL IN THE VEHICLE

⚠ CAUTION

- Please do not fail to operate in the temperature above 15 °C. If the temperature is lower than 15 °C, warm the installing surface with drier before installation.
- Clean off the dirt or oil spot on the installing surface completely with solvent-laden clean cloth.
- Please do not peel off after fixed. Otherwise, adhesive power decreases or breakage may happen.
- Please do not wash the car for 24 hours after installation.
- The procedures and figures shown here is for RH only. For LH, apply the same procedures as shown in RH.

Mazda Motor Corporation

3-1, Shinch, Fuchu-cho, Aki-gun Hiroshima

- This kit includes protective film (2) and a paper pattern which are not included in composition.

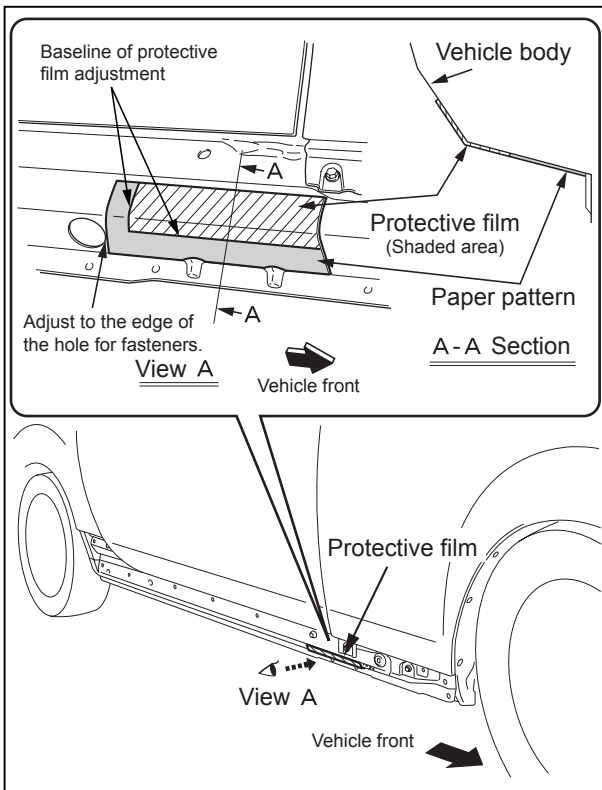

1. After cut out the paper pattern, allocate it to the vehicle body before the installation of side air dam skirt and apply it with tape.
2. Mist the diluted neutral detergent fully on the installing surface.
3. Apply the protective film after confirm the position of protective film using paper pattern.



CAUTION

- Do not touch the adhesive face of protective tape. Dirt or grease may cause the decrease in adhesive power and peeling off.

4. Press it using squeegee until it attaches to the body securely.



CAUTION

- Squeeze out the water with squeegee from the clearance between protective tape and body. Otherwise, peeling-off may occur.
- Press well using squeegee. Otherwise, peeling-off may occur.

5. If air bubbles enter between protective tape and body, make a hole with marking pin and remove the air with squeegee.

4

REMOVING THE VEHICLE COMPONENTS



CAUTION

- When the body is scratched in removing the side air dam skirt, repair the body using touch-up pen to prevent from rusting.
- In removing side air dam skirt, do not fail to remove the fasters from vehicle body.

3

PREPARATORY WORK BEFORE INSTALLATION

Tools used (Have them ready at hand before starting the work)

- ◆ Phillips screwdriver
- ◆ Flathead screwdriver
- ◆ Soft cloth

CAUTION

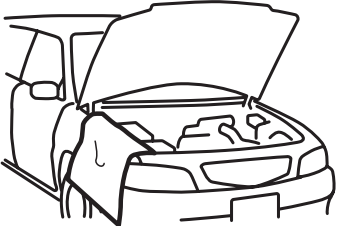
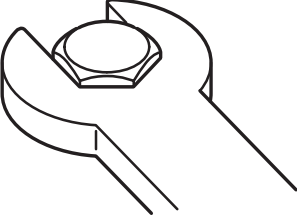
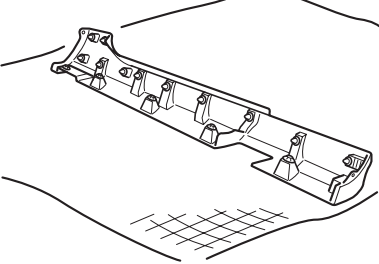
Use a mat or any other protective material when removing/installing components. Otherwise, breakage of components may occur.	Place the removed parts and components on a protective sheet or equivalent to avoid any damage on such parts / components.	Place the removed parts and components on a protective sheet or equivalent to avoid any damage on such parts/components.
		

Note

- Consult the service manuals for the vehicle for the instructions on the removal and installation of the vehicle components.

WARNING

- Make sure that operation is carried out on the level ground with the P range, parking brake and chock block set.

4

REMOVING THE VEHICLE COMPONENTS

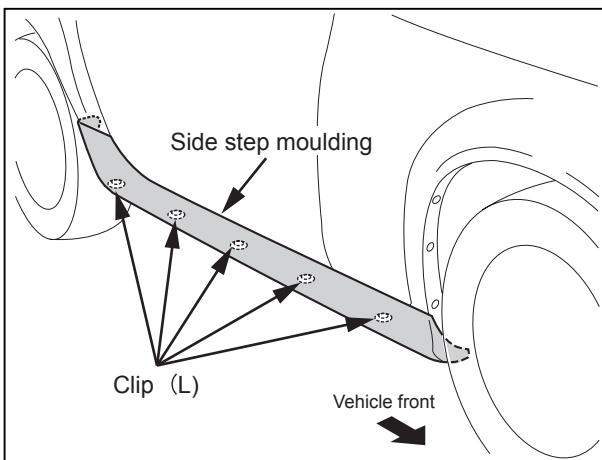
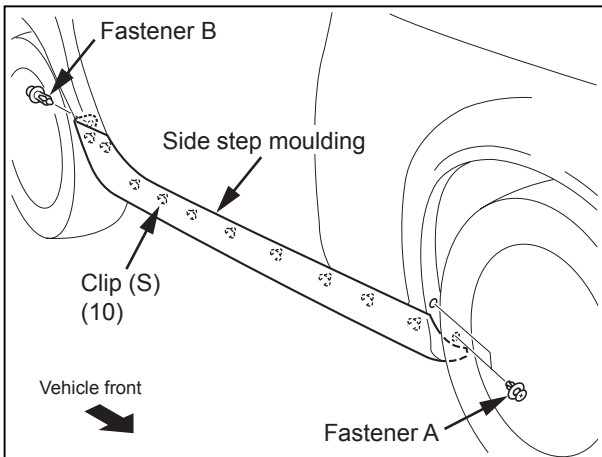

NOTE

- Only the right-hand side is shown here, but carry out the same procedure for the left-hand side too.

Side step moulding (Accessory) removal

1. Remove the two fasteners A and the fastener B that are secured to the side step moulding. (These will be reused during installation.)
2. Use a screwdriver to disengage the ten small clips that are on the side of the side step moulding.



CAUTION

- When removing the fasteners, reshape the fastener mounting holes if they become bent.

3. Disengage the five large clips at the bottom of the side step moulding, and then remove the side step moulding from the vehicle.



CAUTION

- When removing the clips, reshape the clip mounting holes if they become bent.

5

SIDE AIR DAM SKIRT INSTALLATION

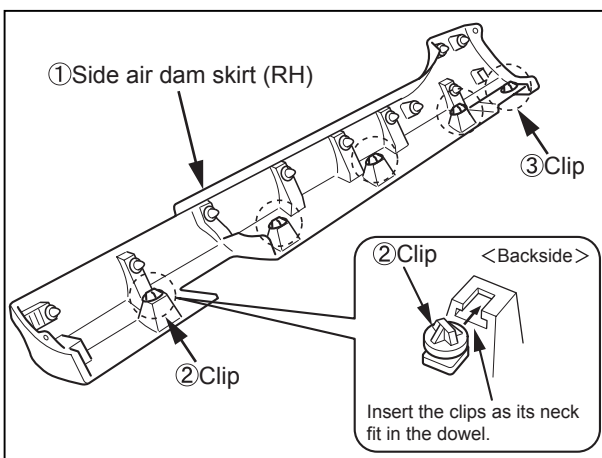

NOTE

- Only the right-hand side is shown here, but carry out the same procedure for the left-hand side too.

Side air dam skirt installation

1. Install the side air dam skirt (R.H.) ① with the five clips. (clip (1) ②, clips (4) ③)

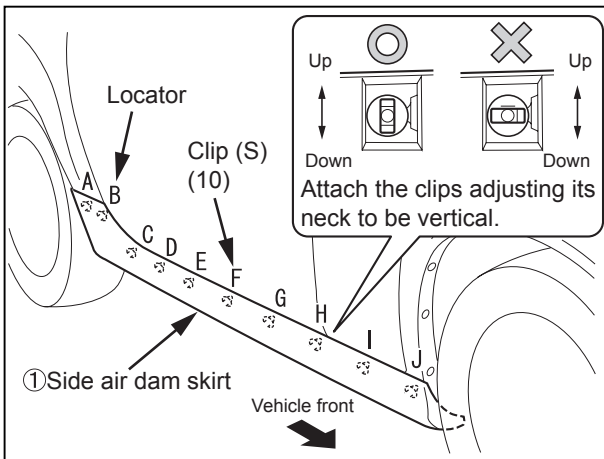

2. To prevent false locking, adjust the eleven clips of the side air dam skirt ① (R.H.) so that they are sideways. (Refer to the diagram at left.)
3. Gently push the eleven clips into the vehicle mounting holes, starting with B and going from B to A, B to K.



CAUTION

- Insert the side air dam skirt at the front of the vehicle in between the vehicle body and the mudguard and then attach the small clips

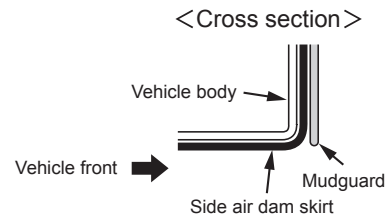

4. Fix the clips ② ③ that were attached in the procedure 1. to the vehicle mounting holes.
5. Install the two fasteners A and the fastener B that were removed from the side step moulding in step 1. of "4. REMOVING THE VEHICLE COMPONENT" in reverse.

To customers



CAUTION

- Never put your feet on the side air dam skirt while the vehicle is stopped, as it can be very dangerous. When driving on roads that are extremely rough, lower the vehicle speed and drive very carefully. If these precautions are not observed, the mounting area may become damaged.

Installation Inspection Sheet

[To be used by installation workshop]

MX-5	SIDE AIR DAM SKIRT
	NF51 V4 910F

Inspection items after installation

- Inspect the installed parts and removed and re-installed parts following the items below.

Section to be inspected	Inspection item (circle)			
	Gap / fit & finish	Scratch, stain, tape residue	Tightening & engagement	Function
Side air dam skirt	<input type="radio"/>	<input type="radio"/>	<input type="radio"/>	
Mudguard	<input type="radio"/>	<input type="radio"/>	<input type="radio"/>	

Side air dam skirt installation inspection

Date		(year/month/day):			
VIN: No.					
Approved		Checked		Prepared	

✂ Retention period of the sheet: 3 months