

REAR SPOILER

Installation Instructions

Applicable model : Mazda MX- 5

Part Number : QNCA 51 960

Thank you for purchasing a Genuine Mazda accessory.

Before removal and installation, you are expected to carefully read these instructions.

To use it in its best conditions, be sure to read thoroughly these instructions for full understanding of the contents and to properly use it.

< Cautions and Requests >

- ⚠ CAUTION and ⚠ WARNING marks shown in these instructions indicate safely precautions, which you are requested to strictly comply with during installation and use.

⚠ WARNING : Indicates a situation in which serious injury or death could result if the warning is ignored.

⚠ CAUTION : Indicates a situation in which bodily injury or damage to the vehicle could result if the caution is ignored.

- Do not install the rear spoiler in any way other than described in the following instructions.
- Do not modify the rear spoiler.
- To ensure safety and reliability of the work, installation, removal and disposal work must be carried out by an authorized Mazda Dealership.
- If you have any questions about the use of the accessory, ask your Mazda dealer for proper advice before using it.
- We may not accept the liability for any problems that might have occurred due to non-compliance with these instructions.
- Be careful not to lose removed parts, and be sure they are kept free from scratches, grease or other dirt.

To the dealer

Please turn over these instructions to the customer after installation.

To the customer

- Keep these instructions after installation. The instructions may be necessary for installing other optional parts or removal of this accessory.
- Should the vehicle or this accessory be resold, always leave these instructions with it for the next owner.

1

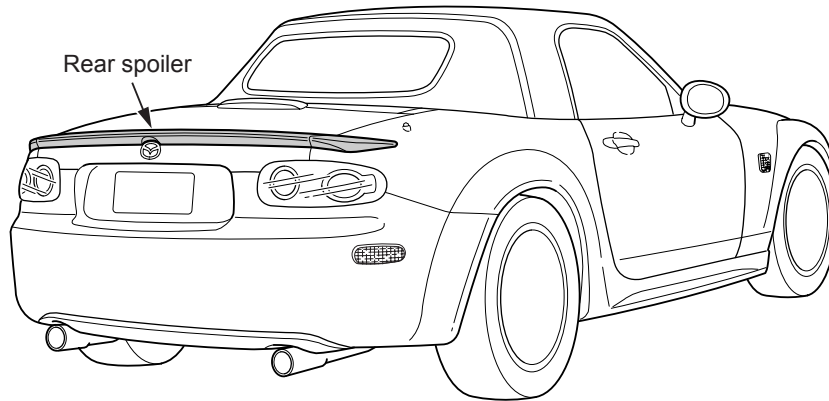
AS-COMPLETED

2

COMPONENTS**CAUTION**

- Make sure that there is no missing component based on the following parts list and check the components for any dirt, scratches or other damage.
- When install rear spoiler and front bumper face together, ⑤ air guide, ⑥ clip nut and ⑦ bolt are not used.

No.	Part name	Q'ty	Part number
①	Rear spoiler (Center)	1	_____
②	Rear spoiler (RH)	1	_____
③	Rear spoiler (LH)	1	_____
④	Clip	8	G18K 51SJ3
⑤	Air guide	1	QNCA-50-A20
⑥	Clip nut	4	_____
⑦	Bolt	4	_____
⑧	Template (drilling and positioning)	1set	_____
⑨	Installation instructions	1	_____

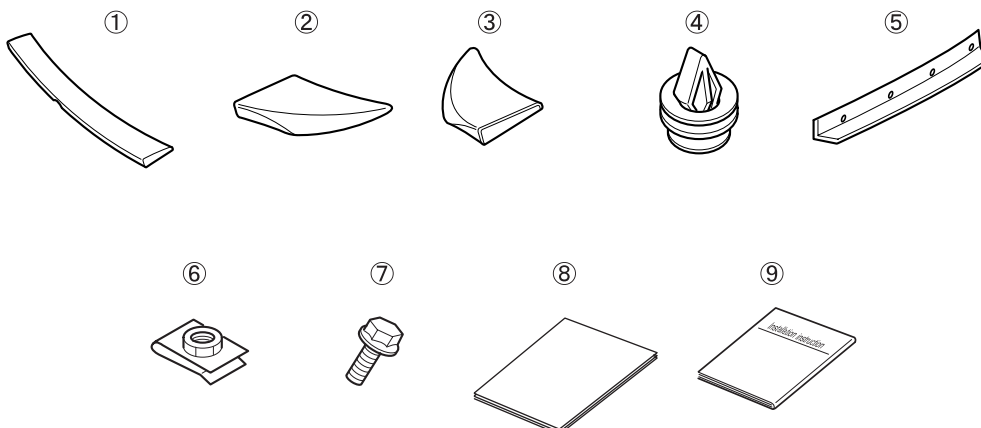

3

PREPARATORY WORK BEFORE INSTALLATION

Tools used (Have them ready at hand before starting the work)

- ◆ Tape
- ◆ Punching
- ◆ Scissors
- ◆ Cleaner, air gun
- ◆ Torque wrench
- ◆ IPA (isopropyl alcohol) or white gasoline
- ◆ Touch-up paint (genuine parts)
- ◆ Electric drill (ϕ 3mm, ϕ 5mm, ϕ 7mm, ϕ 9mm, ϕ 10mm)
- ◆ Flat Blade screw driver with protective sheet
- ◆ Nipper
- ◆ Cutter
- ◆ Sealing agent (Genuine)
- ◆ Hammer
- ◆ Phillips screwdriver
- ◆ Round file
- ◆ Soft cloth, protective sheet
- ◆ Socket wrench (7mm)

CAUTION

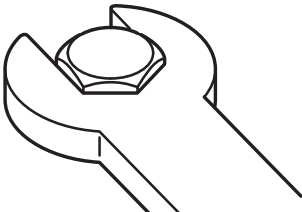
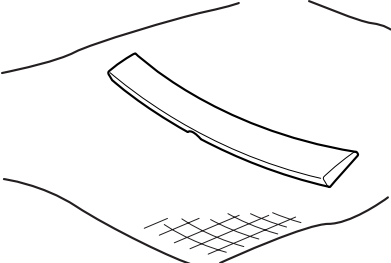
Use a mat or any other protective material when removing/installing components. Otherwise, breakage of components may occur.	Use right tools appropriate for the purpose and size of the work to be done to ensure proper execution of the work.	Place the removed parts and components on a protective sheet or equivalent to avoid any damage on such parts / components.
		

Note

- As for the removal or installation of vehicle parts, please refer to the vehicle workshop manual.

WARNING

- Make sure that operation is carried out on the level ground with the P range, parking brake and chock block set.

CAUTION

- When tightening a bolt, nut and screw, be sure to use torque wrench and the specified torque. Otherwise, improper connection, breakage or damage of the installed parts may occur.
- For unpainted rear spoiler, please see important points in painting and follow the instruction.

4

INSTALLATION OF THE REAR SPOILER

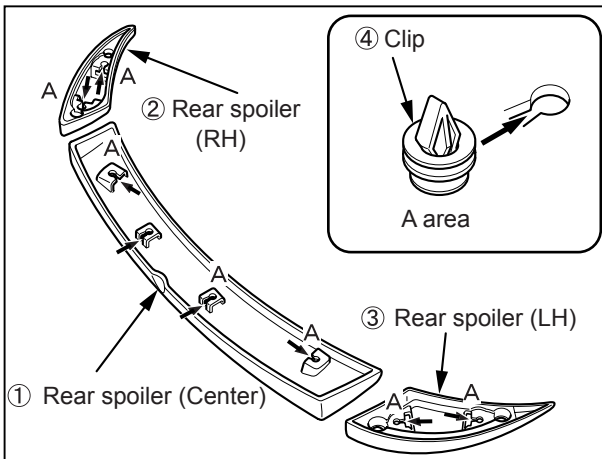

Preparation of rear spoiler installation

1. Attach the ④ clips to the backside of the ① rear spoiler (center) and ② rear spoiler (RH) and ③ rear spoiler (LH).

- ① Rear spoiler (Center) : 4 locations
- ② ③ Rear spoiler (RH/LH) : 2 locations for each



CAUTION

- Please perform the installation operation with a soft cloth under the rear spoiler to protect the parts.

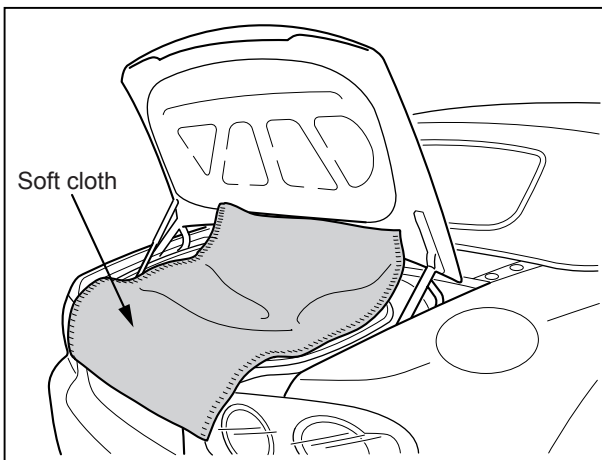

Vehicle protection

1. Before drilling holes on the trunk lid, cover the vehicle body with a soft cloth to protect from chips.

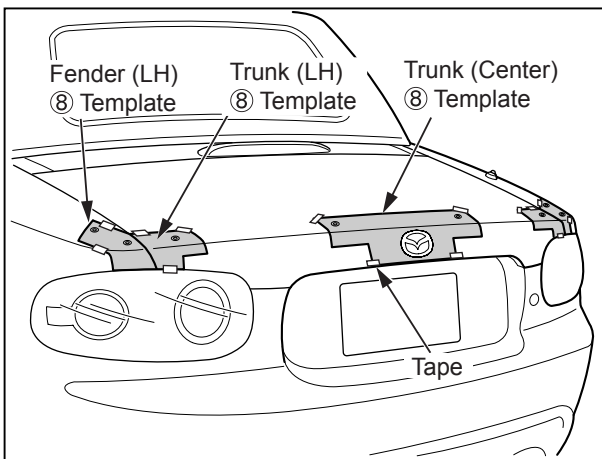

Drilling hole

1. Cut out the ⑧ template (total 5 sheets) along the cut-off line.
2. Align the ⑧ template, and secure the ⑧ template with tape.
 - Trunk (Center) template :
Align with mascot and edge of the trunk lid.
 - Trunk (LH/RH) template :
Align with the edge of the trunk lid.
 - Fender (LH/RH) template :
Align with the edge of the fender.

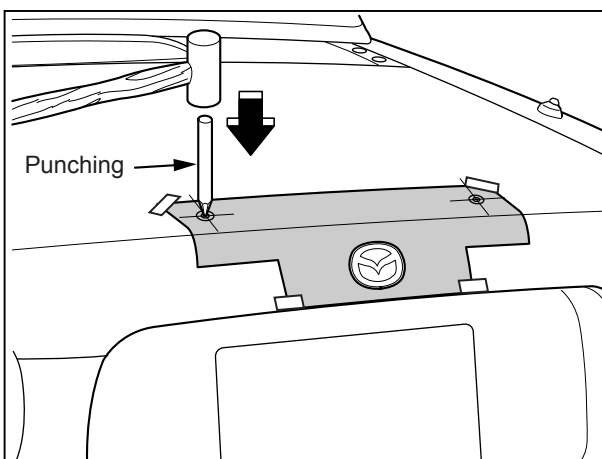

3. Lightly punch a drill guide mark on the trunk lid.



CAUTION

- Before punching, please make sure again that the templates are aligned with trunk lid and fender.
- Don't punch the trunk lid and the fender hard. Otherwise, it may deform.

4. Remove the ⑧ template from the trunk lid.

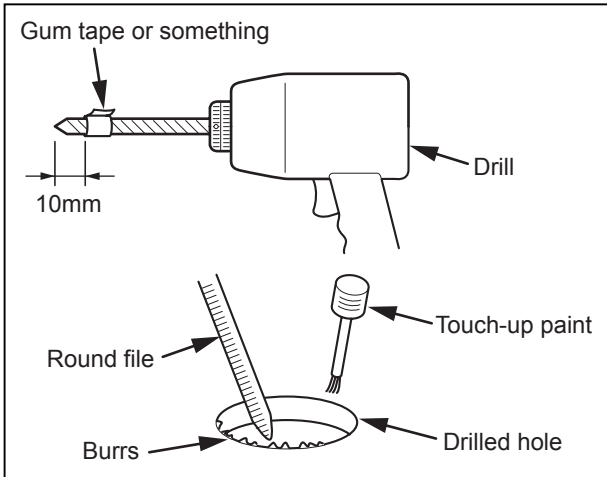

5. Set the drill rotation to low speed.
6. Wrap the drill bit with tape as shown in the figure



CAUTION

- Always use a drill with a rotation speed adjustment, otherwise the trunk lid may deform
- Be careful when handling drills and other sharp objects.
- To prevent scratching and over-drilling, always wrap the drill bit with gum tape.

7. Drill the marked point in a direction perpendicular to the trunk lid.
8. First drill with a $\phi 3\text{mm}$ bit, $\phi 5\text{mm}$ bit, $\phi 7\text{mm}$ bit, $\phi 9\text{mm}$ bit and finish with a $\phi 10\text{mm}$ bit.
9. Remove the burrs from the edge of the holes with round file.



CAUTION

- Make sure to remove burrs from the surface so that the trunk lid is smooth.

10. Clean the chips.



CAUTION

- Completely remove drill fillings from the trunk and cabin, otherwise they may cause abnormal noise.

11. Clean the trunk lid with IPA (isopropyl alcohol).
12. Apply a seal coating for rust prevention, and spread touch-up paint after drying.



CAUTION

- Sure to prevent rusting properly.

13. Remove the soft cloth protecting the vehicle.

Installation of the rear spoiler (Center)

1. Peel off the edge of each adhesive backings toward the outside of the ① rear spoiler (Center).



CAUTION

- Do not remove the adhesive backings excessively.

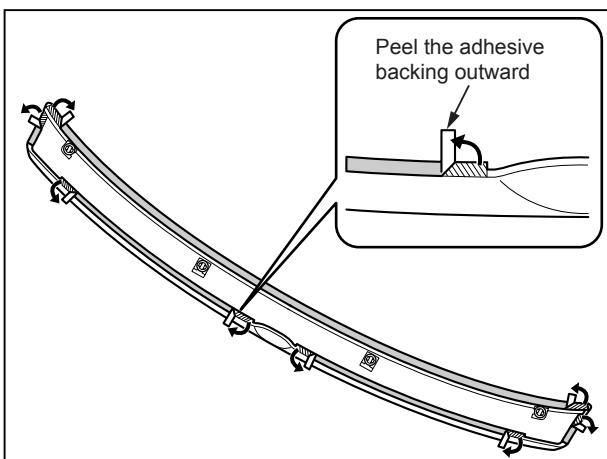

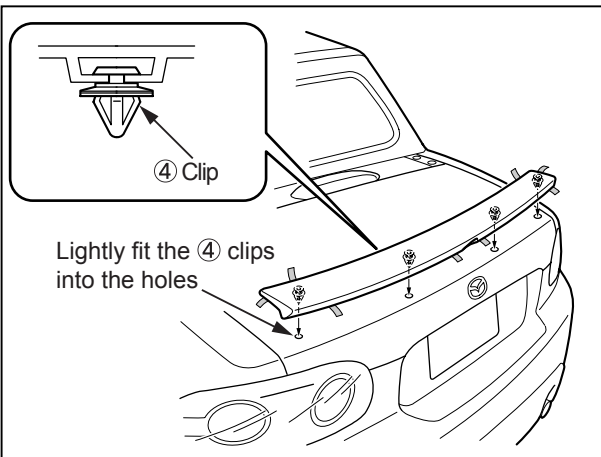

2. Hold both ends of the ① rear spoiler, lightly fit the ④ clips into the four holes on the trunk lid.



CAUTION

- Do not insert the grommet completely. Otherwise, the double-side adhesive tape on the backside of the rear spoiler will affix to the trunk lid, and the installation position cannot be adjusted.

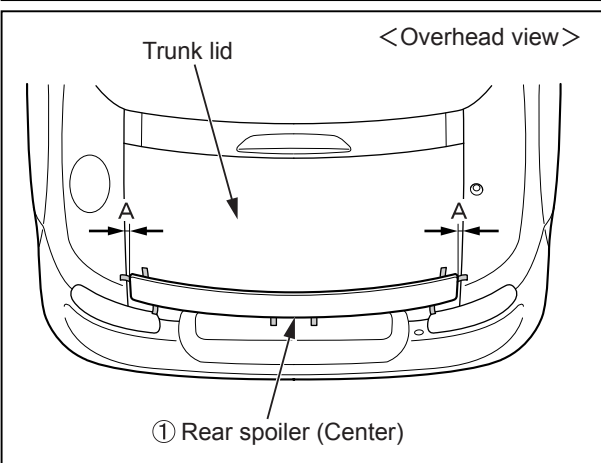

3. Adjust the right and left clearance in A area to be equal.



CAUTION

- Misalignment of the installing position may cause not only poor showing but also in collect. So be sure to adjust the clearance of both ends to be equal.

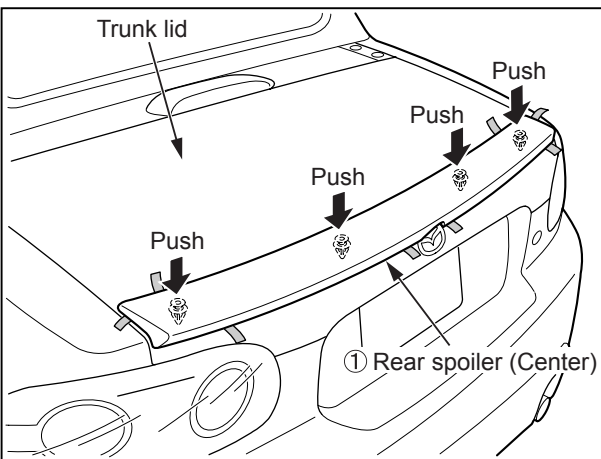

4. Insert the clips into the holes.



CAUTION

- Insert the clips slowly. If the clips are pushed with excessive force, the clips and the trunk lid will deform, an bit may cause difficulty in fitting them in.

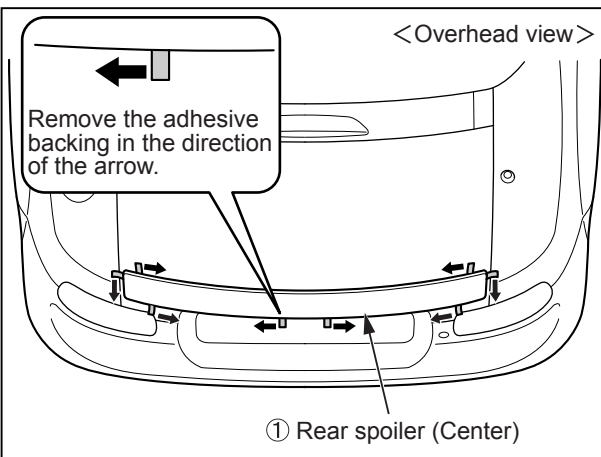

5. Remove the double-faced adhesive backing of the ① rear spoiler (Center) in the direction of arrow, and affix securely.



CAUTION

- Perform the installation with raising the rear spoiler from the trunk lid so that the adhesive backing tape wouldn't be torn.
- Don't remove the product once affixed. Adhesive force will be reduced.

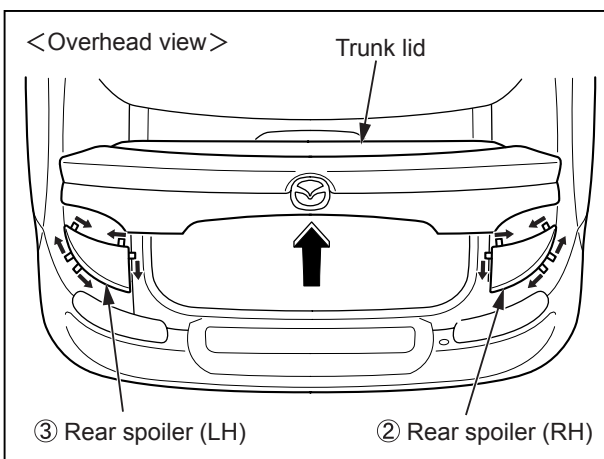
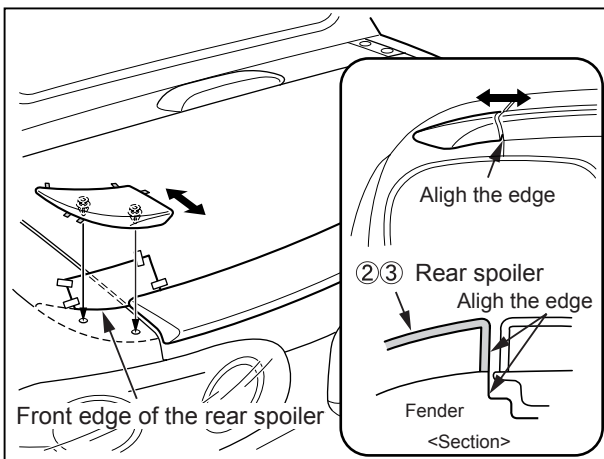
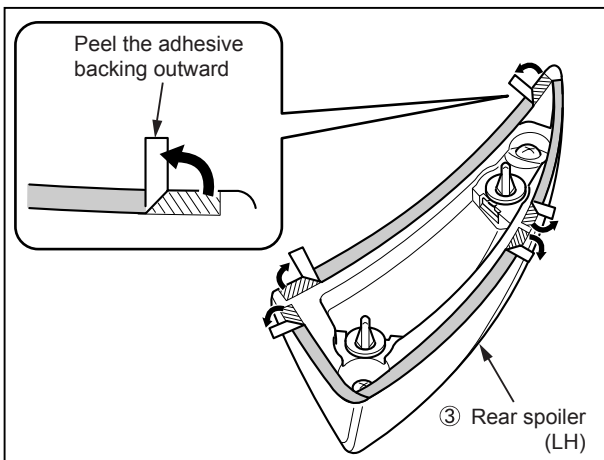
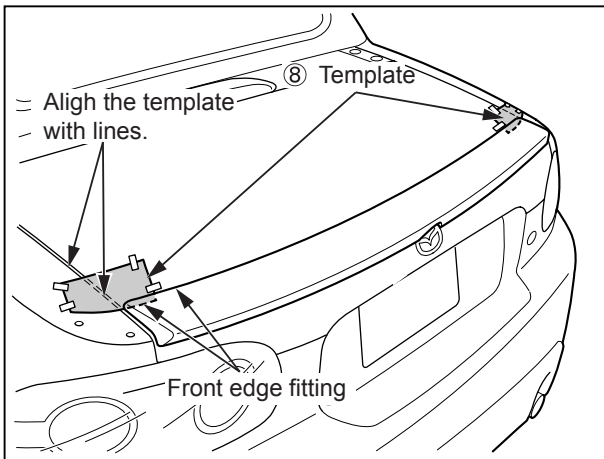

Installation of the rear spoiler (RL/LH)

1. Cut out the ⑧ template with scissors along the cutting-off line.
2. Align the template according to the instructions and secure the template with tape.

3. Peel the edge of each adhesive backing outward the rear spoiler.

CAUTION

- Do not remove the tape backings excessively.

4. Lightly fit the clips into the holes on the fender.
5. Align the front edge of the ② ③ rear spoiler (LH/RH) to the edge of the ⑧ template to determine.
6. Align the sections of both the fender and the ② ③ rear spoiler (LH/RH) to the dividing between the trunk lid and the fender in order to determine the lateral position.
7. Insert the clips securely.

8. Remove the ⑧ template.
9. Open and close the trunk lid to check that ② ③ rear spoiler (LH/RH) doesn't interfere and there's no misalignment of ① ② ③ rear spoilers, and close the trunk lid.
10. Remove the adhesive backings in the direction of the arrow and affix securely.

5

INSTALLATION OF THE AIR GUIDE

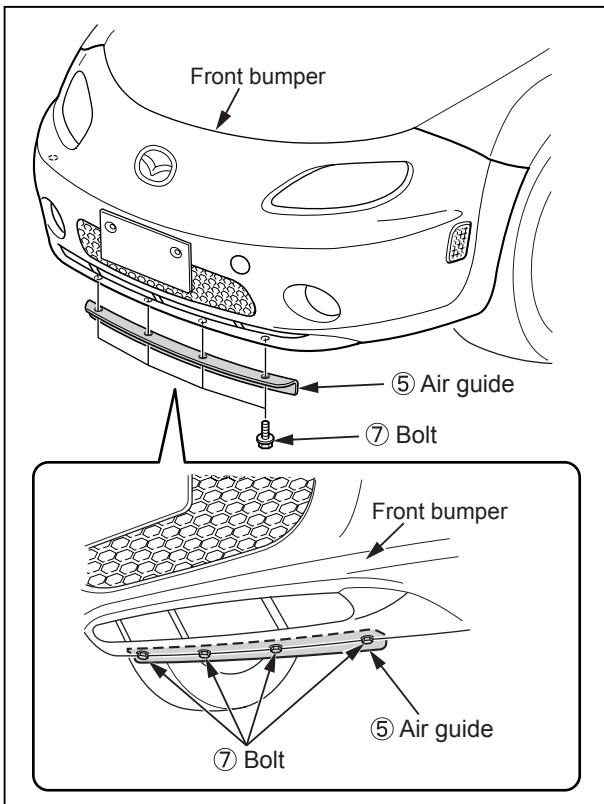
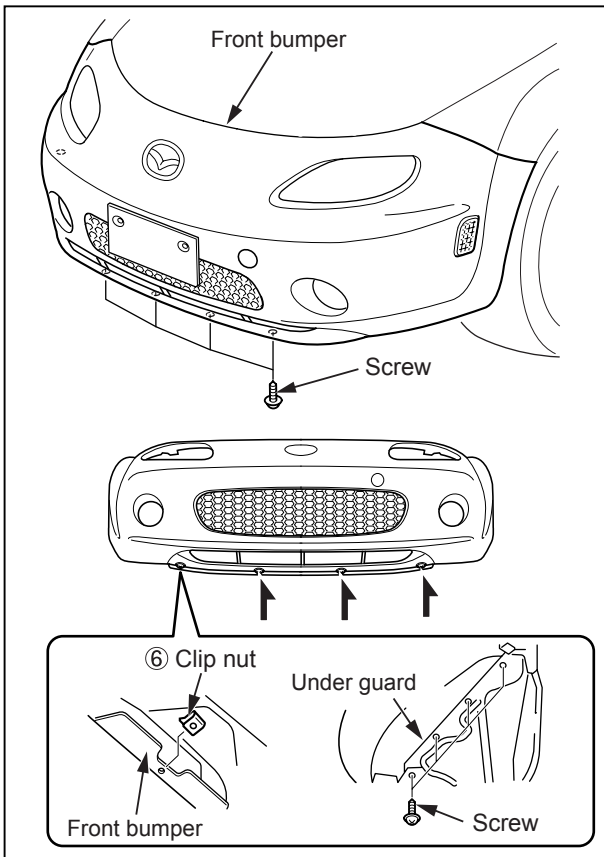

When not install the front bumper face together

1. Remove the screws that hold the under cover, and remove the four clip nuts that are attached to the front bumper.

NOTE

- The removed screws and clip nuts are not reused for this accessory.

2. Install the four ⑥ clip nuts in the position where formerly clip nuts were installed.

3. Install the ⑤ air guide as shown in the figure and tighten it with the four ⑦ bolts.

Tightening torque

Bolt : 1.4~1.5N · m

<Vehicle with out front air dam skirt>

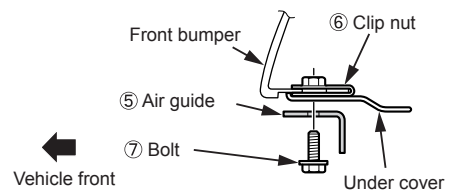

<Vehicle with front air dam skirt>

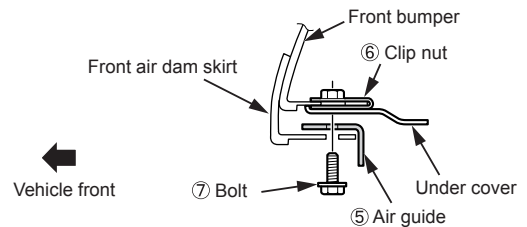

CAUTION

- Make sure the bolt is tightened securely.
Make sure to tighten to the specified torque.
If tightened outside the specified torque, the air guide could be damaged or fall off..

Installation Inspection Sheet

[To be used by installation workshop]

Mazda MX-5	REAR SPOILER
	QNCA 51 960

Inspection items after installation

- Inspect the installed parts and removed and re-installed parts following the items below.

Section to be inspected	Inspection item (circle)			
	Gap / fit & finish	Scratch, stain, tape residue	Tightening & engagement	Function
Rear spoiler	○	○	○	
Trunk lid		○		
Fender		○		
Air guide	○	○	○	

Rear spoiler installation inspection

Date		(year/month/day):			
VIN: No.					
Approved		Checked		Prepared	

※ Retention period of the sheet: 3 months