



GENUINE REAR SPOILER

INSTALLATION INSTRUCTIONS

Thank you for purchasing a genuine Mazda accessory.
Before removal and installation, be sure to thoroughly read these instructions.
Please read the contents of this booklet in order to properly install and use the rear spoiler. Your safety depends on it.
Keep these instructions with your vehicle records for future reference.

WARNING

- There are several  **WARNING** and  **CAUTION** sections in this booklet concerning safety when installing or removing the rear spoiler. Always read and follow them in order to prevent injuries, accidents, and possible damage to the vehicle.

 **WARNING:** Indicates a situation in which serious injury or death could result if the warning is ignored.

 **CAUTION:** Indicates a situation in which bodily injury or damage to the vehicle could result if the caution is ignored.

- Do not modify the rear spoiler.
- Do not install the rear spoiler in any way other than described in the following instructions.
- If in any doubt, please ask your Mazda dealer to install the accessory in order to prevent errors in installation.
- If you have any questions about the use of the accessory, ask your Mazda dealer for proper advice before using it.
- Mazda and its suppliers are not responsible for injuries, accidents, and damage to persons and property that arise from the failure of the dealer or installer to follow these instructions.
- To ensure safety and reliability of the work, installation, removal and disposal work must be carried out by an Authorized Mazda Dealership.
- Be careful not to lose removed parts, and be sure that they are kept free from scratches, grease or other dirt.

PART NAME: REAR SPOILER
PART NUMBER: NF51 V4 920G
VEHICLE: MX-5

Note

To the dealer

- Please turn over these instructions to the customer after installation.

To the customer







- Keep these instructions after installation. The instructions may be necessary for installing other optional parts or removal of this accessory.
- Should the vehicle or this accessory be resold, always leave these instructions with it for the next owner.

1. PARTS

Parts list

NOTE

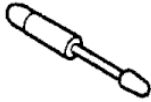
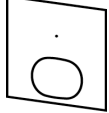
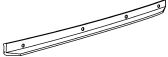
- Before installation, verify that the kit includes all the following parts and that they are free of dirt, scratches, or damage.

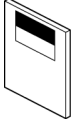
Part	Part name	Qty	Part	Part name	Qty	Part	Part name	Qty
	Rear spoiler	1		Grommet	1		Cap	1
	Packing	1		Stay damper (NF80 56 930)	2		Template	1
	Air guide QNCA-50-A20	1		Bolt	4		Clip nut	4
	Installation instructions	1						

Installation view

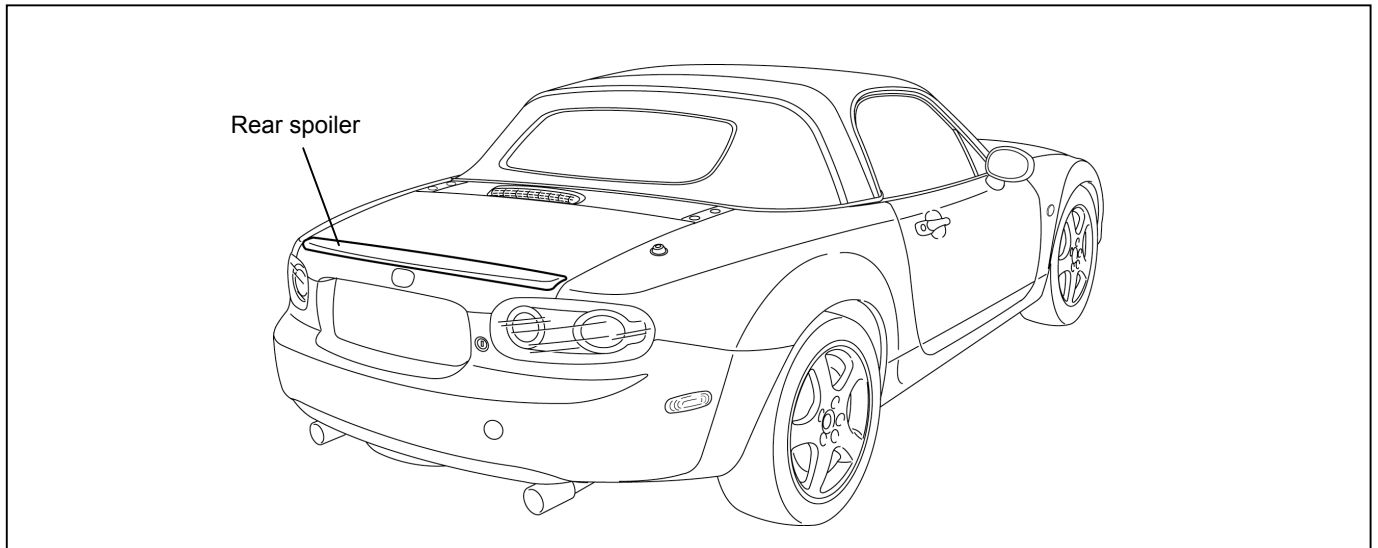

2. REQUIRED TOOLS

Electric drill (3 mm, 5 mm, 7 mm, 9 mm, 11 mm, 13 mm drill bits)

Flathead screwdriver wrapped with Protective tape

Nipper

Round file

Punch

Cutter knife

Scissors Tape Sealant Soft, clean cloth

Touch-up paint (Genuine product)

Isopropyl alcohol (IPA)

3. BEFORE INSTALLATION

⚠ CAUTION

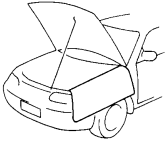
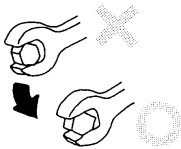
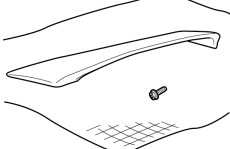
<p>Be sure to cover the vehicle body With protectors or mats to prevent stains, scratches and damage when removing/installing the vehicle parts</p>	<p>Use the most appropriate (size, use) tool for each task and perform the may be damaged.</p>	<p>Place the removed parts and kit accessories on a protective sheet to prevent scratches.</p>
		

NOTE

- Refer to the Workshop Manual for removal and installation of vehicle parts. Not following the procedures for removal/installation in the Workshop Manual could result in an accident or vehicle malfunction.

4. REAR SPOILER INSTALLATION

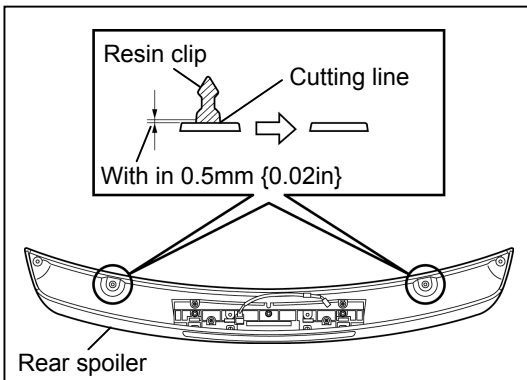

Preparation of rear spoiler installation

1. Cut the two resin clips (shaded area) on the rear spoiler using a nipper, and furnish the surface flat so that the clearance is with 0.5mm {0.02in}

⚠ CAUTION

- Cover the rear spoiler with cloth to prevent damage or scratches on its surface.

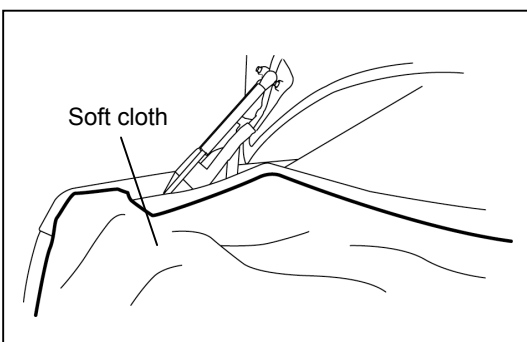

Vehicle protection

1. Before drilling holes on the trunk lid, be sure to completely cover the opening with a soft cloth to protect the body.

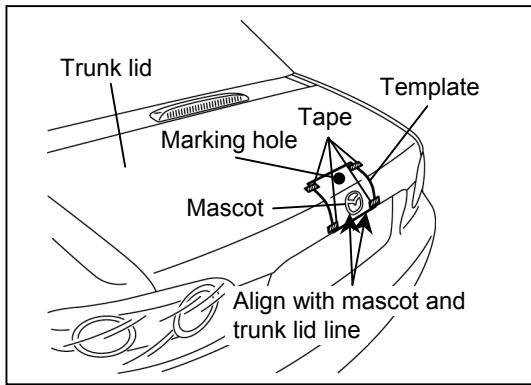

Body hole drilling

1. Align the template with the mascot and the trunk lid line, and secure the template with tape.

⚠ **CAUTION**

- Make sure the template is not detached when affixing it to the body.
- Attach the template with the marking hole aligned to the center of the trunk lid.

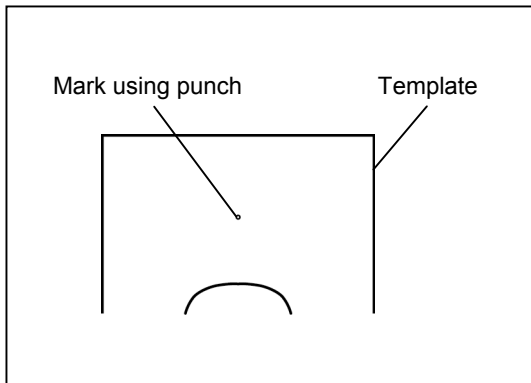

2. Punch a drill guide mark in the center of the rear spoiler installation position (1 location) using a punch.

⚠ **CAUTION**

- Before marking with the punch, verify again that the marking hole position on the template is aligned to the center of the trunk.
- When drilling holes, relocate and secure the wiring harness for the license plate with tape so that it does not interfere.
- Do not punch the trunk lid hard, otherwise it may deform.

3. Remove template from the trunk lid.

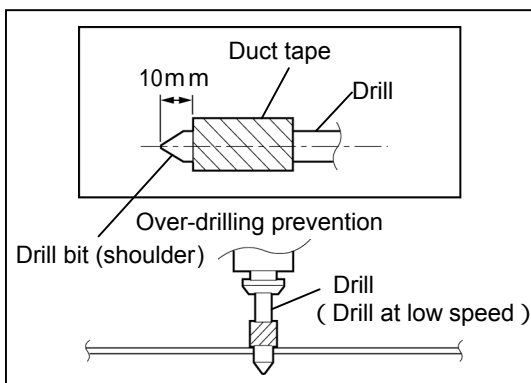

4. Set the drill rotation to low speed.
5. Wrap the drill bit with duct tape as shown in the figure.

⚠ **CAUTION**

- Always use a drill with a rotation speed adjustment, otherwise the trunk lid may deform.
- Be careful when handling drills and other sharp objects.
- To prevent scratching and over-drilling, always wrap the drill bit with duct tape.

6. Make successive holes on the marked area perpendicular to trunk lid using drills.

Drilling: 3mm 5mm 7mm 9mm 11mm 13mm (1 location)

7. Remove any burrs around the drilled hole with a round file.

⚠ **CAUTION**

- Make sure to remove burrs from the surface so that the trunk lid surface is smooth.

8. Blow off chips as with air gun.

⚠ **CAUTION**

- Completely remove drill filings from the trunk and cabin, otherwise they may cause abnormal noise.

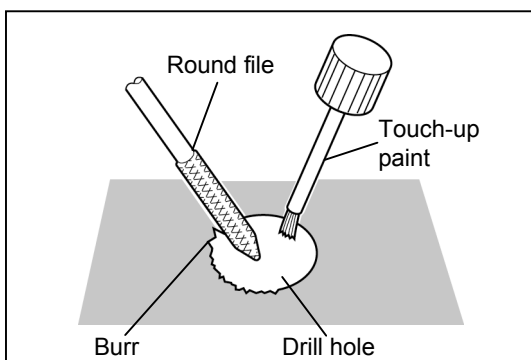

9. Use a soft cloth dampened with IPA (isopropyl alcohol) to clean the surface of the vehicle where the side under spoiler is to be installed.

10. Apply sufficient sealant to prevent rust.

11. After the sealant has dried, apply touch-up paint.

12. Remove the soft cloth protecting the vehicle.

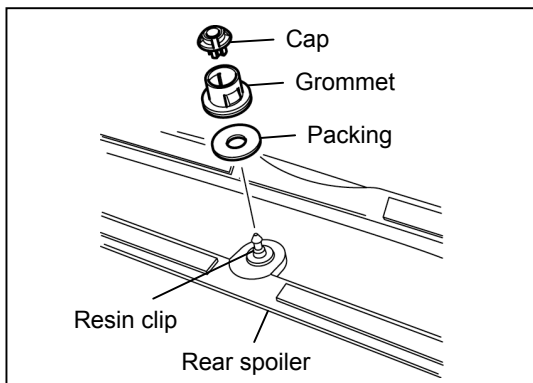

Component parts of rear spoiler installation

1. Remove the tape backing from the packing, and affix to the resin clip on the backside of the rear spoiler (center position).
2. Install the grommet, then the cap to the rear spoiler.

⚠ CAUTION

- If they are not installed in the correct order, the grommet and cap cannot be securely installed.

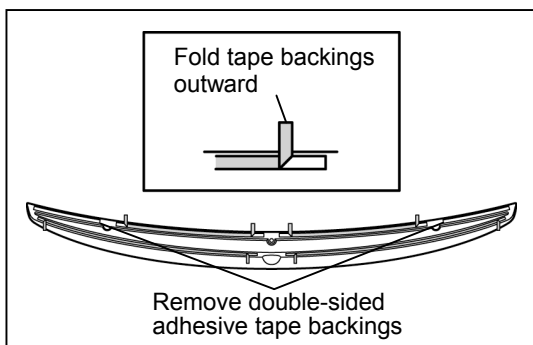

Rear spoiler installation

1. Peel off the paper backing of the double-sided adhesive tape. (2 locations)
2. Fold the double-sided adhesive tape (4 locations) outward so that they can be removed easily.

⚠ CAUTION

- Do not remove the tape backings excessively.

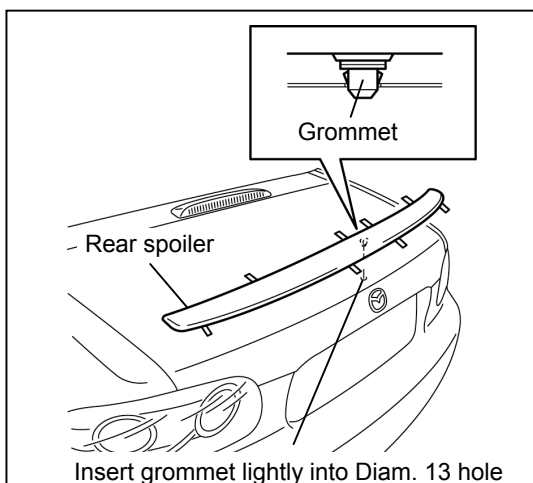

3. Hold both ends of the rear spoiler and align the grommet of the rear spoiler with the installation hole (Diam. 13 mm) of the trunk lid and insert lightly.

⚠ CAUTION

- Do not insert the grommet completely. Otherwise, the double-sided adhesive tape on the backside of the rear spoiler will affix to the trunk lid, and the installation position cannot be adjusted.

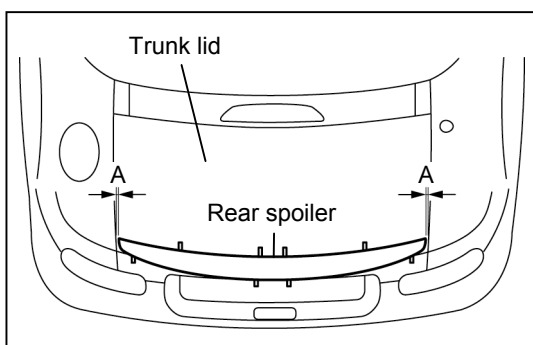

4. Align so that clearance A on both ends is even with the installation position.

⚠ CAUTION

- Make sure that the removed double-sided adhesive tape (2 locations) does not affix to the trunk lid.

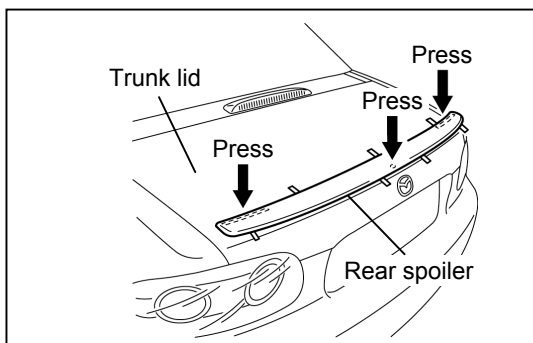

5. Pull in the grommet from the surface of the rear spoiler and install to the trunk lid.

⚠ CAUTION

- Tuck in grommet slowly. If the grommet is pushed in with excessive force, the grommet or the trunk lid will deform and it may be difficult to insert.

6. Affix the double-sided adhesive tape removed in Step 1 (2 locations) to the trunk lid.

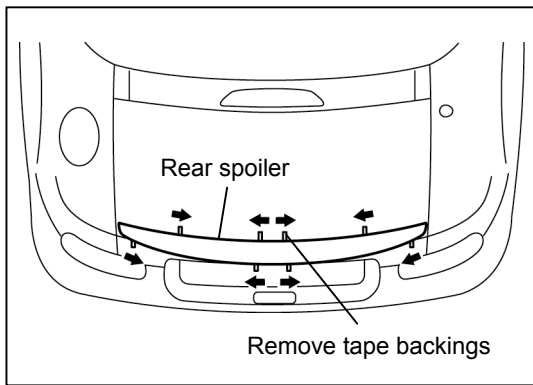

7. Remove the double-sided adhesive tape backings from the rear spoiler and affix securely.

⚠ CAUTION

- Keep the rear spoiler slightly away from the trunk lid to prevent the release-coated paper from being torn.
- Do not separate the taped areas once the tape has adhered, otherwise the subsequent adhesion performance will be greatly reduced.

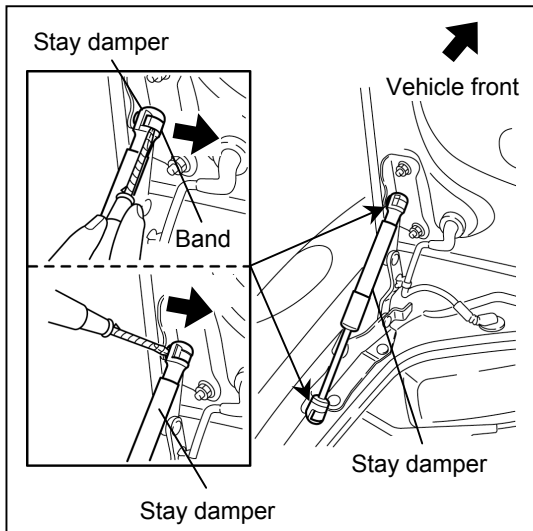

Stay damper removal / installation

⚠ WARNING

- Removing the trunk lid without supporting is dangerous. The trunk lid may fall and injure you. Open the trunk lid fully and support it before removing the stay damper. Always perform these procedures together with at least another person.

1. Using a flathead screwdriver, remove the stay damper bands (2 each side).
2. Remove the stay damper from the body and trunk lid.
3. Install stay dampers (LH/RH) of the kit parts.

NOTE

- Remove and install the stay dampers one by one.
- The figure shows the left side, however, perform the same procedure for the right side.
- The removed stay dampers are not used for this accessory.

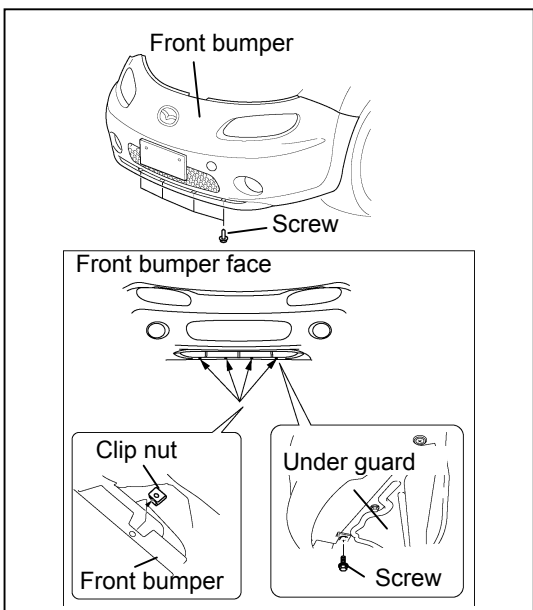

Air guide installation

1. Remove the under guard installation screws (2 locations each side from front bumper center), and then remove the clip nuts (4) installed to the front bumper.

⚠ CAUTION

- The removed screw and clip nut are not used to install this accessory.

2. Install the kit clip nuts (4) to the locations where the front bumper clip nuts were installed.

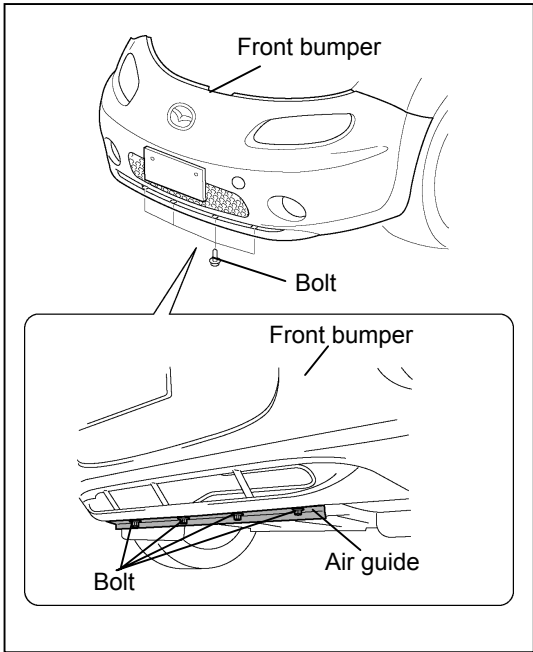

3 . Install the air guide as shown in the figure and tighten it with the kit bolts (4).

Tightening torque

Bolt : 1.4 - 1.5 N·m {14.0 - 15.0 kgf·cm · 12.4 – 13.2 in·lbf }

⚠ CAUTION

- Make sure the bolt is tightened securely. Make sure to tighten to the specified torque. If tightened outside the specified torque, the air guide could be damaged or fall off.

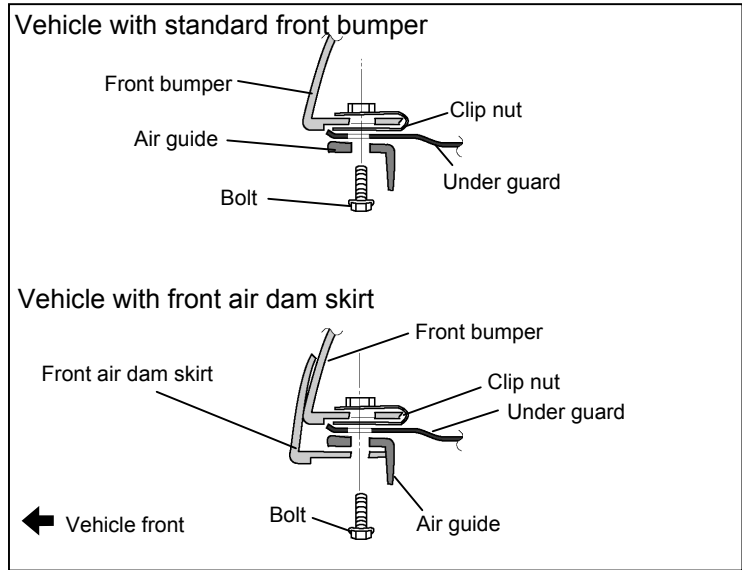

INSTALLATION INSPECTION SHEET

MX-5

REAR SPOILER

NF51 V4 920G

Inspection items after installation

- Inspect the installed/reinstalled parts for the following items:

Part	Check Item ()			
	Clearance/Fit	Scratches/Dirt/ Remaining tape	Installation/ Tightening/ Engagement	Rust proofing
Trunk lid				
Stay damper				
Rear spoiler				
Air guide				

Installation inspection sheet for rear spoiler

Date				
VIN.				
Approved		Checked		Person in charge

The term of validity for this sheet: 3 months