



GENUINE REAR SPOILER

INSTALLATION INSTRUCTIONS

Thank you for purchasing a genuine Mazda accessory.
Before removal and installation, be sure to thoroughly read these instructions.
Please read the contents of this booklet in order to properly install and use the rear spoiler. Your safety depends on it.
Keep these instructions with your vehicle records for future reference.

WARNING

- There are several  **WARNING** and  **CAUTION** sections in this booklet concerning safety when installing or removing the rear spoiler. Always read and follow them in order to prevent injuries, accidents, and possible damage to the vehicle.

 **WARNING:** Indicates a situation in which serious injury or death could result if the warning is ignored.

 **CAUTION:** Indicates a situation in which bodily injury or damage to the vehicle could result if the caution is ignored.

- Do not modify the rear spoiler.
- Do not install the rear spoiler in any way other than described in the following instructions.
- If in any doubt, please ask your Mazda dealer to install the accessory in order to prevent errors in installation.
- If you have any questions about the use of the accessory, ask your Mazda dealer for proper advice before using it.
- Mazda and its suppliers are not responsible for injuries, accidents, and damage to persons and property that arise from the failure of the dealer or installer to follow these instructions.
- To ensure safety and reliability of the work, installation, removal and disposal work must be carried out by an Authorized Mazda Dealership.
- Be careful not to lose removed parts, and be sure that they are kept free from scratches, grease or other dirt.

PART NAME: REAR SPOILER
PART NUMBER: NH52 V4 920
0000 8Y D06
VEHICLE: MX-5

Note

To the dealer

- Please turn over these instructions to the customer after installation.

To the customer





- Keep these instructions after installation. The instructions may be necessary for installing other optional parts or removal of this accessory.
- Should the vehicle or this accessory be resold, always leave these instructions with it for the next owner.

1. PARTS

Parts list

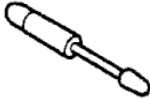
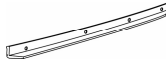
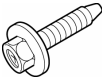
NOTE

- Before installation, verify that the kit includes all the following parts and that they are free of dirt, scratches, or damage.

Part	Part name	Qty	Part	Part name	Qty	Part	Part name	Qty
	Rear spoiler	1		Stay damper (NF80 56 930)	2		Air guide	1
	Bolt	4		U-nut	4		Template	2
	Installation instructions	1						

Installation view

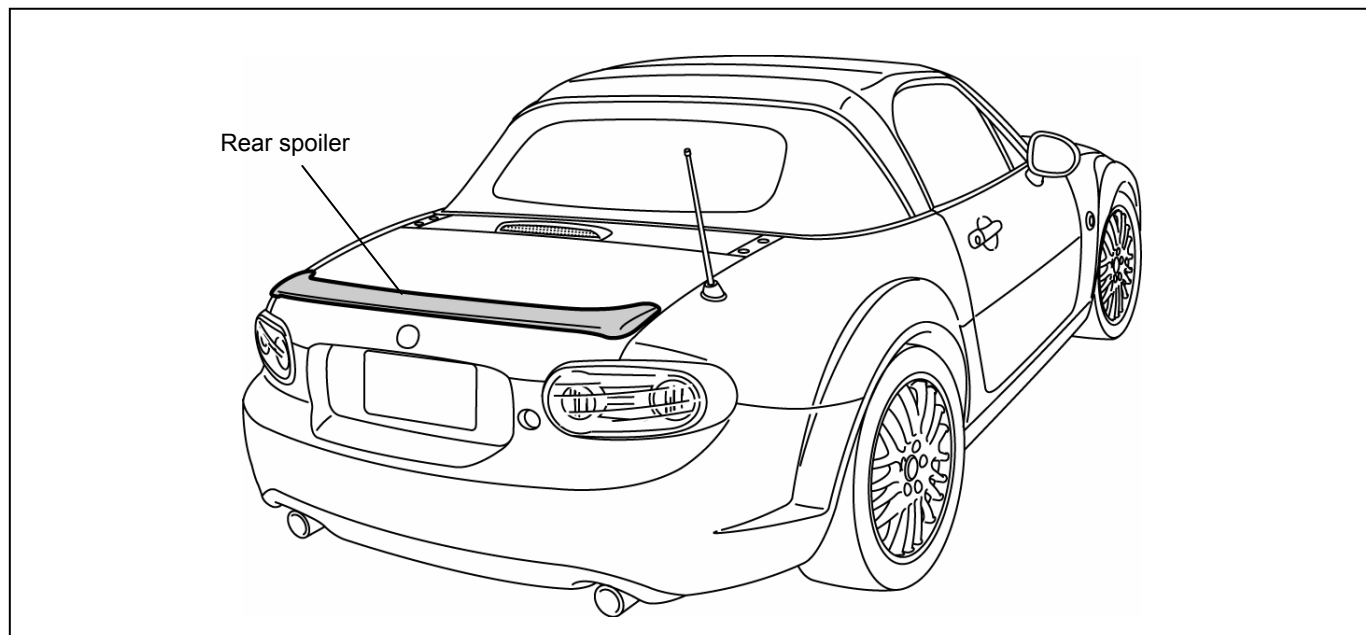

2. REQUIRED TOOLS

- ☆ Drill (3 mm, 5 mm, 7 mm, 9 mm drill bits)
- ☆ Flathead screwdriver wrapped with Protective tape
- ☆ Nipper
- ☆ Round file
- ☆ Punch
- ☆ Cutter knife
- ☆ Tape
- ☆ Sealant
- ☆ Soft, clean cloth
- ☆ Touch-up paint (Genuine product)
- ☆ Isopropyl alcohol (IPA)

3. BEFORE INSTALLATION

⚠ CAUTION

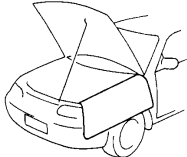
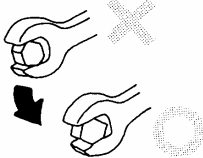
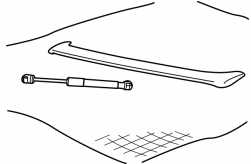
<p>Be sure to cover the vehicle body with protectors or mats to prevent stains, scratches and damage when removing/installing the vehicle parts</p>	<p>Use the most appropriate (size, use) tool for each task and perform the may be damaged.</p>	<p>Place the removed parts and kit accessories on a protective sheet to prevent scratches.</p>
		

NOTE

- Refer to the Workshop Manual for removal and installation of vehicle parts. Not following the procedures for removal/installation in the Workshop Manual could result in an accident or vehicle malfunction.

4. REAR SPOILER INSTALLATION

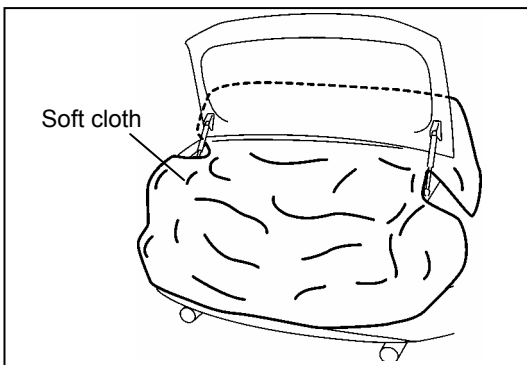

Vehicle protection

1. Before drilling holes on the trunk lid, be sure to completely cover the opening with a soft cloth to protect the body.

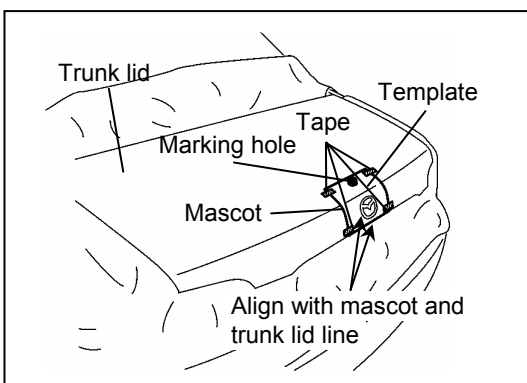

Body hole drilling

1. Align the template with the mascot and the trunk lid line, and secure the template with tape.

⚠ CAUTION

- Make sure the template is not detached when affixing it to the body.
- Attach the template with the marking hole aligned to the center of the trunk lid.

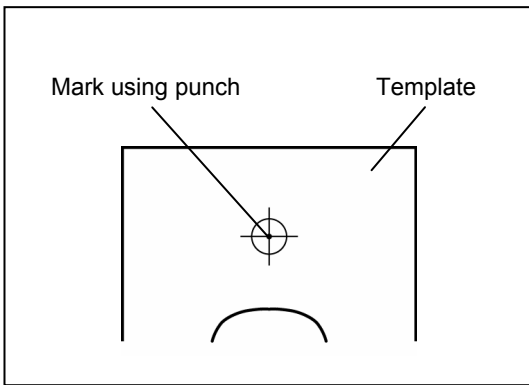

2. Punch a drill guide mark in the center of the rear spoiler installation position (1 location) using a punch.

⚠ CAUTION

- Before marking with the punch, verify again that the marking hole position on the template is aligned to the center of the trunk.
- When drilling holes, relocate and secure the wiring harness for the license plate with tape so that it does not interfere.
- Do not punch the trunk lid hard, otherwise it may deform.

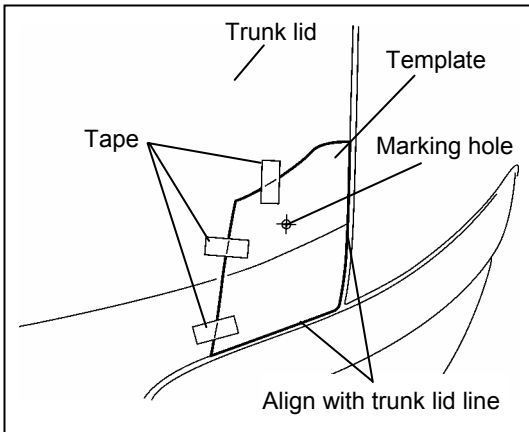

3. Align the template with the trunk lid line, and secure the template with tape.

⚠ CAUTION

- Make sure the template is not detached when affixing it to the body.

NOTE

- The figure shows the right side, however, perform the same procedure for the left side.

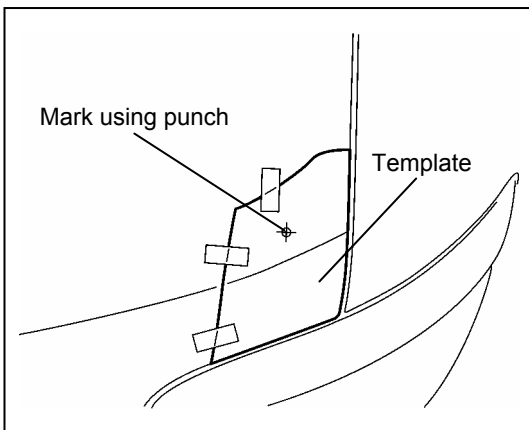

4. Punch a drill guide mark in the center of the rear spoiler installation position (1 location) using a punch.

⚠ CAUTION

- Do not punch the trunk lid hard, otherwise it may deform.

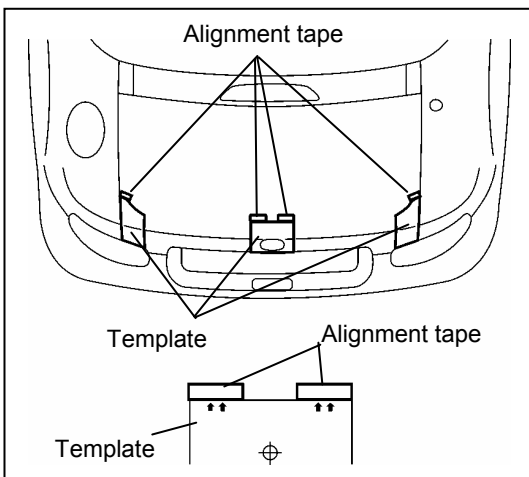

5. Affix alignment tape to the rear spoiler edge line (indicated by arrows) on the template (refer to figure on left).

6. Remove template from the trunk lid.

⚠ CAUTION

- The alignment tape is used for establishing the rear spoiler installation position. Do not remove the alignment tape in this step.

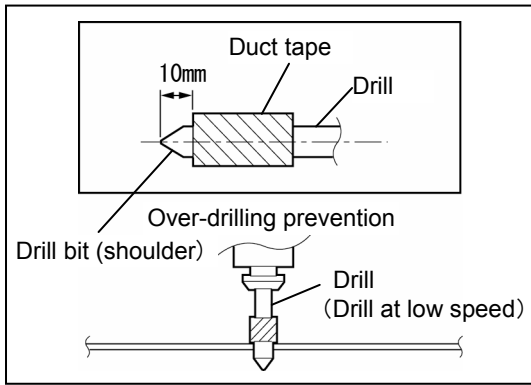

7. Set the drill rotation to low speed.
8. Wrap the drill bit with duct tape as shown in the figure.

⚠ CAUTION

- Do not drill deeper than 10mm.
- Always use a drill with a rotation speed adjustment, and perform work while setting the drill rotation to low speed. Otherwise the aluminum trunk lid may deform because a drill bit can get easily caught in it when drilling.
- Be careful when handling drills and other sharp objects.
- To prevent scratching and over-drilling, always wrap the drill bit with duct tape.

9. Make successive holes on the marked area perpendicular to trunk lid using drills.

Drilling : 3mm→5mm→7mm→9mm (3 locations)

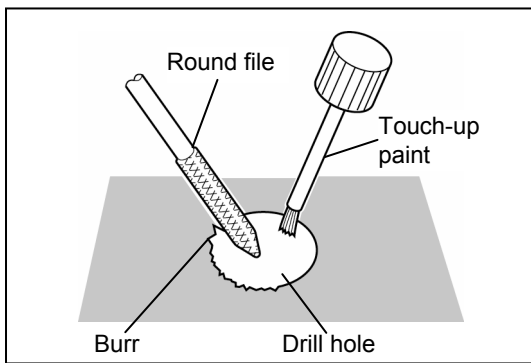

10. Remove any burrs around the drilled hole with a round file.

⚠ CAUTION

- Make sure to remove burrs from the surface so that the trunk lid surface is smooth.

11. Blow off chips as with air gun.

⚠ CAUTION

- Drill shavings can easily fall into the trunk lid, therefore remove them using an air gun.
- Completely remove drill filings from the trunk and cabin, otherwise they may cause abnormal noise.

12. Use a soft cloth dampened with IPA (isopropyl alcohol) to clean the surface of the vehicle where the side under spoiler is to be installed.

13. Apply touch-up paint to the drilled hole.

14. Remove the soft cloth protecting the vehicle.

Rear spoiler installation

1. Peel off the tape backing of the double-sided adhesive tape. (4 locations)
2. Fold the double-sided adhesive tape outward so that they can be removed easily.

⚠ CAUTION

- Do not remove the tape backings excessively.

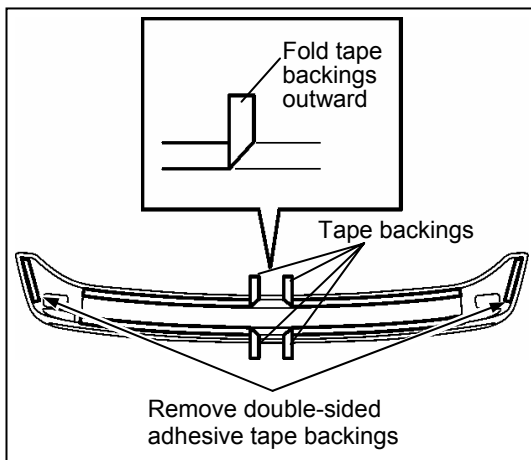

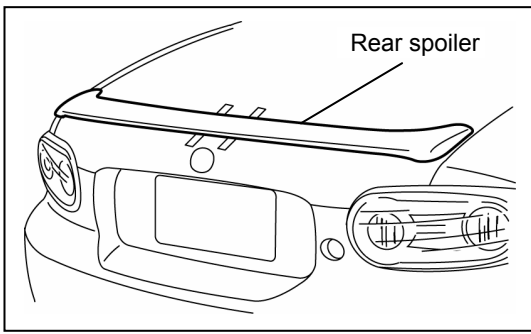

3. Hold both ends of the rear spoiler and align the clips of the rear spoiler with the installation hole (Diam. 9 mm) of the trunk lid and insert lightly.

⚠ CAUTION

- Do not press the rear spoiler firmly. Otherwise, the double-sided adhesive tape on the backside of the rear spoiler will affix to the trunk lid, and the installation position cannot be adjusted.

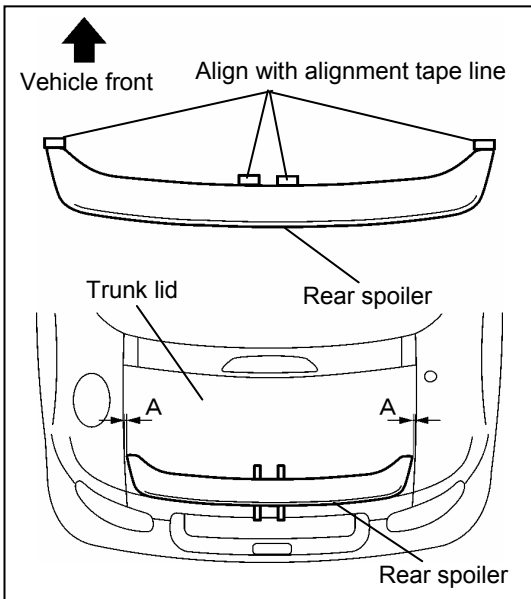

4. Align the rear spoiler with the alignment tape line to establish the rear spoiler front and rear positions.

5. Align the rear spoiler so that the clearance (A) on the left and right positions is even.

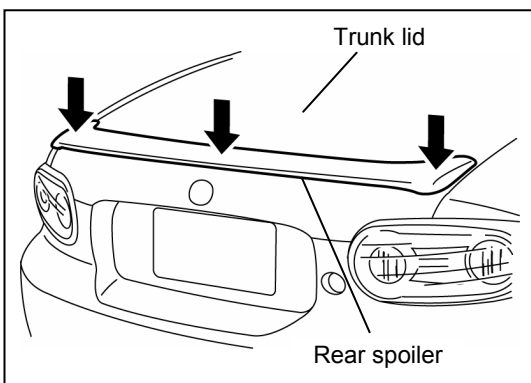

6. Press the locations indicated by the arrows on the rear spoiler to secure it to the trunk lid.

⚠ CAUTION

- Press the rear spoiler locations until the rear spoiler clips engage.

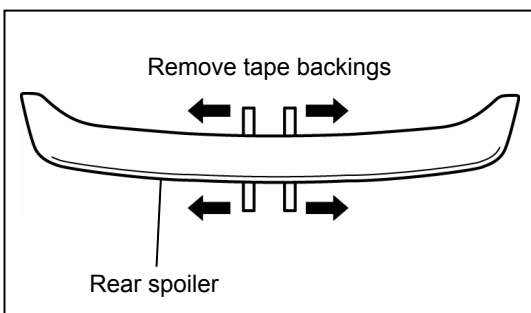

7. Remove the double-sided adhesive tape backings from the rear spoiler and affix securely.

⚠ CAUTION

- Keep the rear spoiler slightly away from the trunk lid to prevent the release-coated paper from being torn.
- Do not separate the taped areas once the tape has adhered, otherwise the subsequent adhesion performance will be greatly reduced.

8. Peel off the alignment tape.

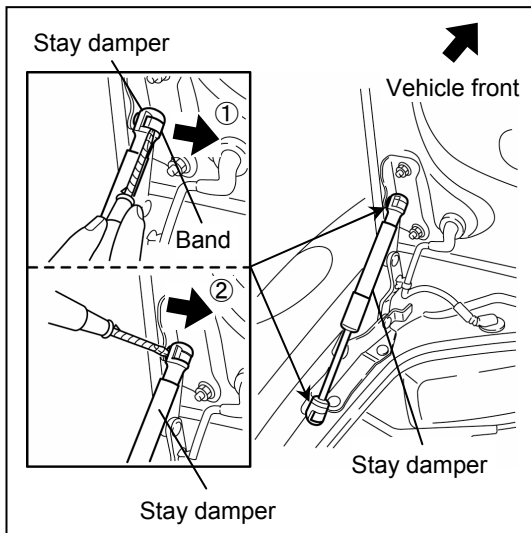

Stay damper removal / installation

⚠ WARNING

- Removing the trunk lid without supporting is dangerous. The trunk lid may fall and injure you. Open the trunk lid fully and support it before removing the stay damper. Always perform these procedures together with at least another person.

1. Using a flathead screwdriver, remove the stay damper bands (2 each side).
2. Remove the stay damper from the body and trunk lid.
3. Install stay dampers (LH/RH) of the kit parts.

NOTE

- Remove and install the stay dampers one by one.
- The figure shows the left side, however, perform the same procedure for the right side.
- The removed stay dampers are not used for this accessory.

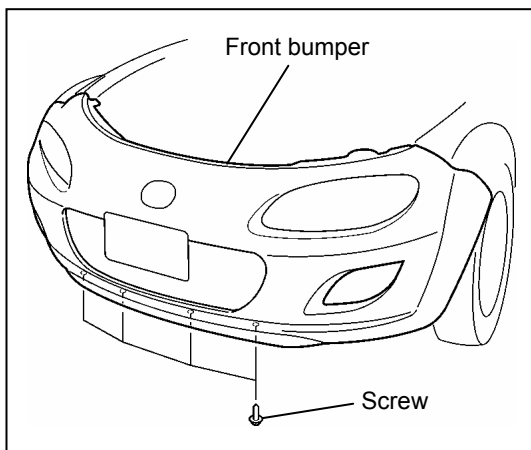

Air guide installation

1. Remove the under guard installation screws (2 locations each side from front bumper center).

⚠ CAUTION

- Removed screws will not be used.

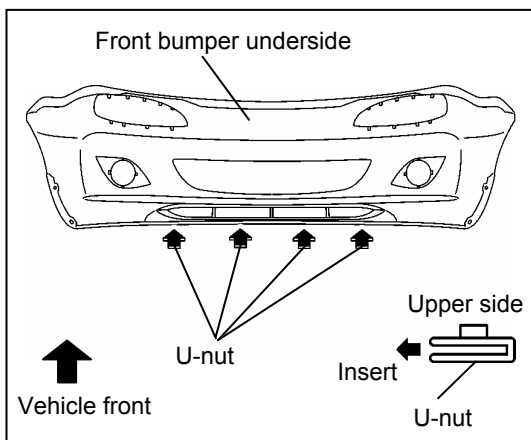

2. Replace the clip nuts (4) under the front bumper with the U-nuts included in the accessory kit.

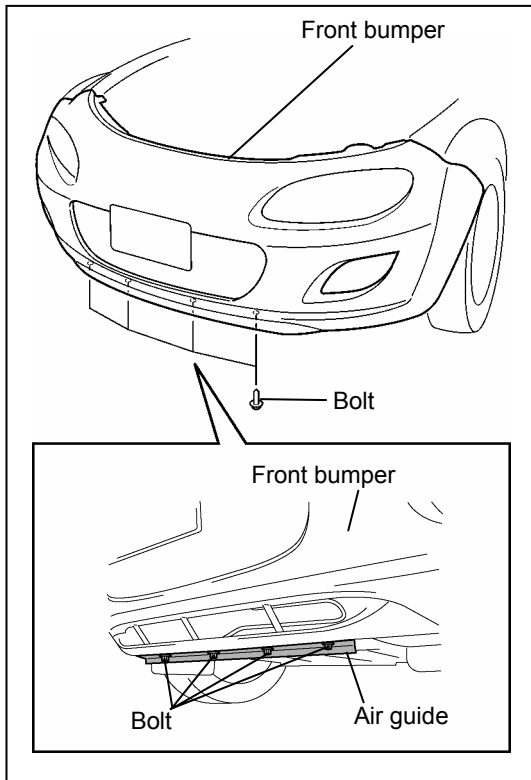

3. Install the air guide as shown in the figure and tighten it with the kit bolts (4).

Tightening torque

Bolt : 4.3–4.7 N·m {44–47 kgf·cm · 38–41 in·lbf}

⚠ CAUTION

- Make sure the bolt is tightened securely. Make sure to tighten to the specified torque. If tightened outside the specified torque, the air guide could be damaged or fall off.

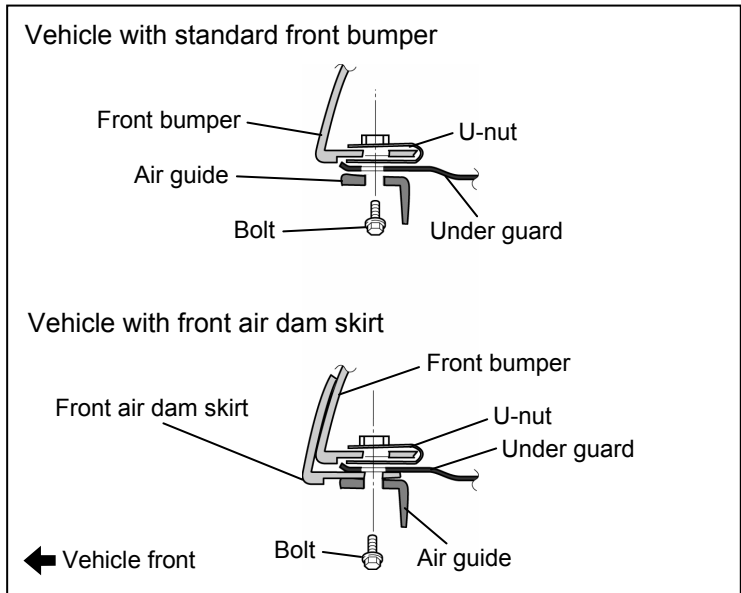

INSTALLATION INSPECTION SHEET

MX-5

REAR SPOILER

NH52 V4 920

0000 8Y D06

Inspection items after installation

- Inspect the installed/reinstalled parts for the following items:

Part	Check Item (○)			
	Clearance/Fit	Scratches/Dirt/ Remaining tape	Installation/ Tightening/ Engagement	Rust proofing
Rear spoiler	○	○	○	
Stay damper	○	○	○	
Trunk lid	○	○	○	○
Air guide	○	○	○	

Important check items

- Inspect the installed / reinstalled parts for the following items.

Page No.	Part name	Tightening torque	Check and write the tightening torque	Person in charge
Air guide installation Step 3 (8 page)	Bolt	4.3—4.7 N·m	N·m	

Installation inspection sheet for rear spoiler

Date _____, _____, _____					
VIN. _____					
Approved		Checked		Person in charge	

The term of validity for this sheet: 12 months

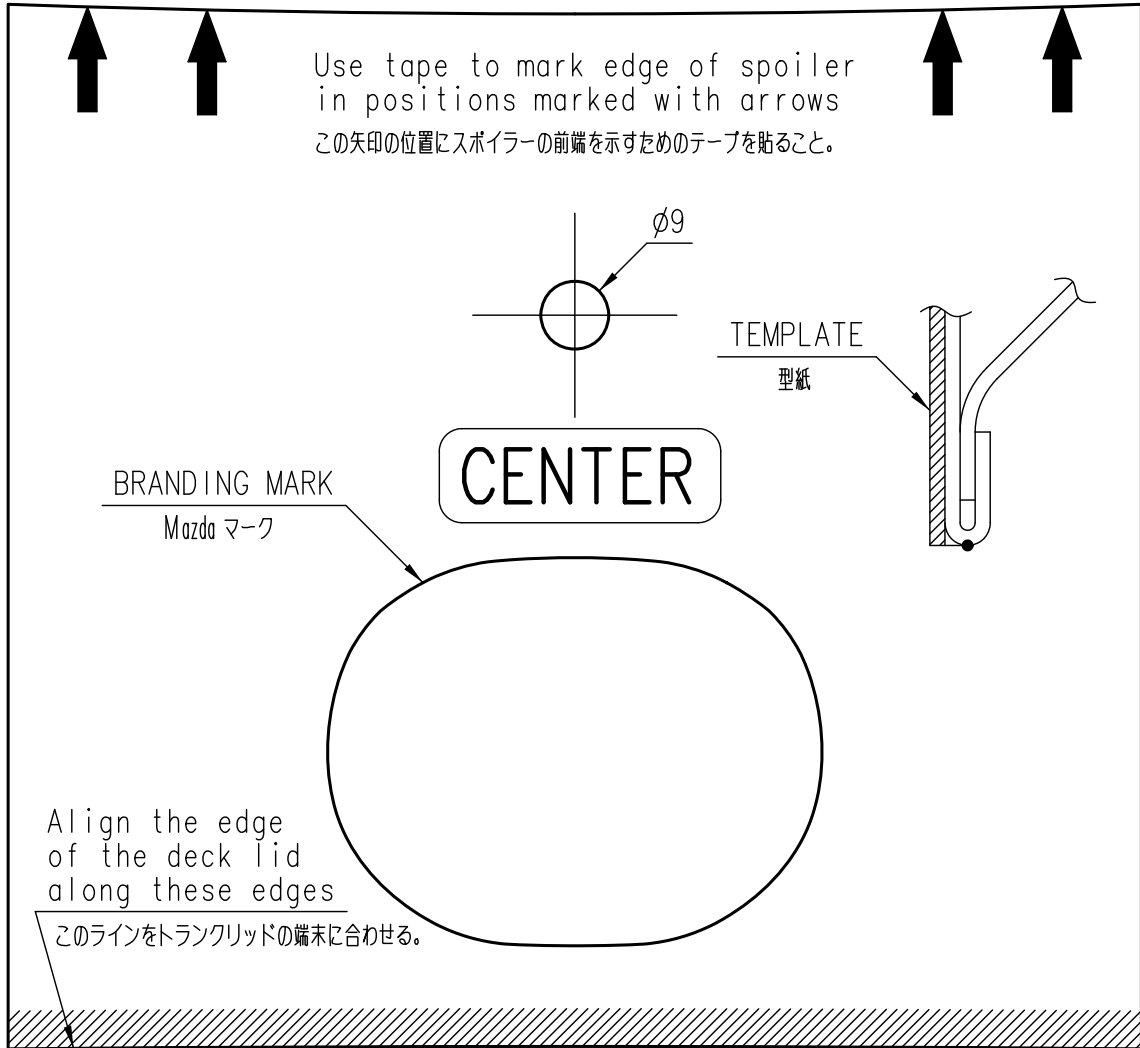

100mm

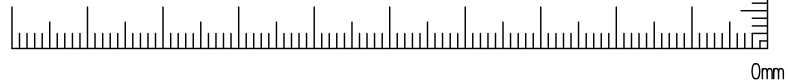

0mm

使用前にスケールの縮尺を確認のこと。

Check above scale to ensure it is 1:1.
Adjust on photocopier if it is not to scale.

(A)

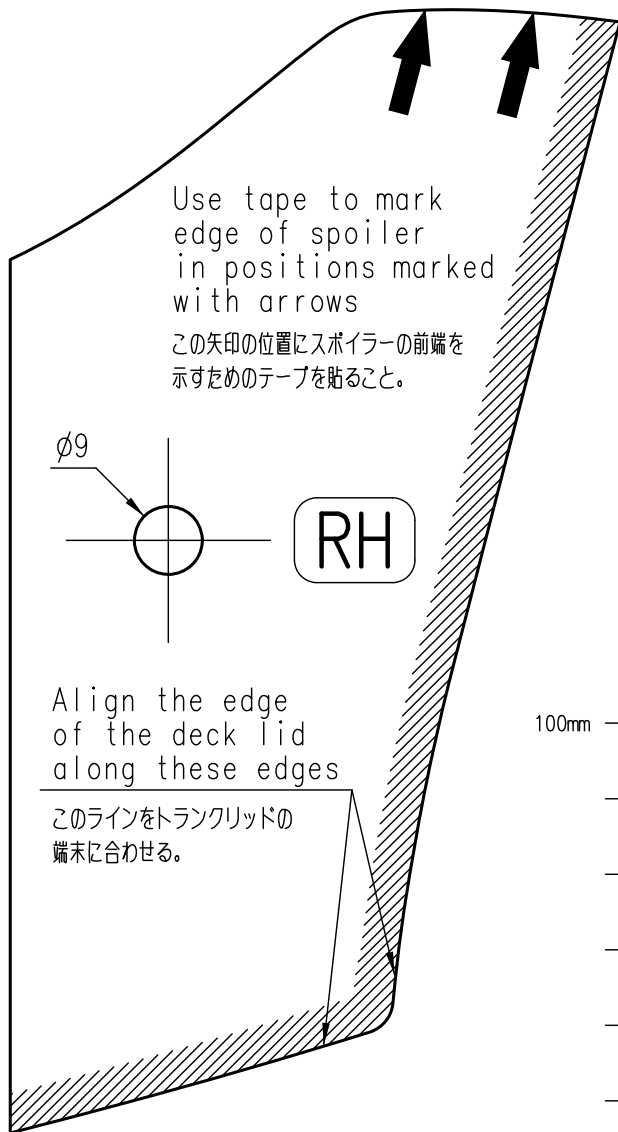
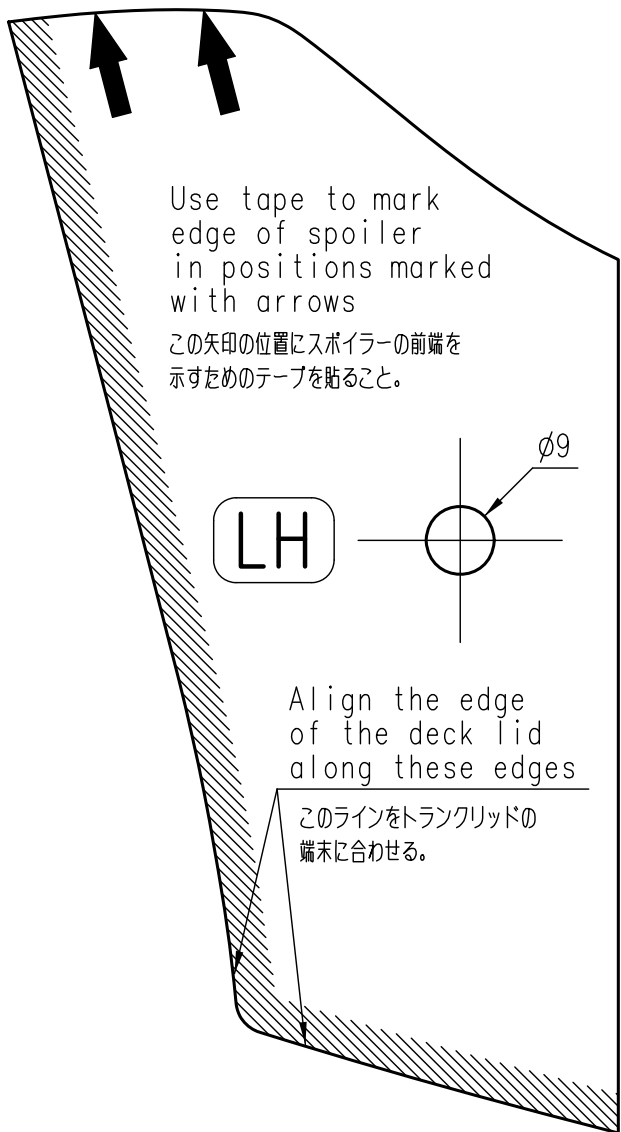

100mm

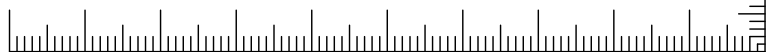

0mm

100mm

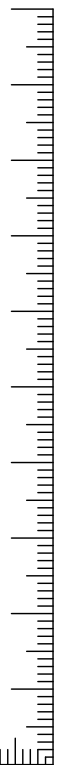

使用前にスケールの縮尺を確認のこと。

Check above scale to ensure it is 1:1.
Adjust on photocopier if it is not to scale. (A)