





GENUINE MUD FLAP (REAR)

INSTALLATION INSTRUCTIONS

Thank you for purchasing a genuine Mazda accessory.
Before removal and installation, be sure to thoroughly read these instructions.
Please read the contents of this booklet in order to properly install and use the mud flap.
Your safety depends on it.
Keep these instructions with your vehicle records for future reference.

WARNING

- There are several  **WARNING** and  **CAUTION** sections in this booklet concerning safety when installing or removing the rear spoiler. Always read and follow them in order to prevent injuries, accidents, and possible damage to the vehicle.
 -  **WARNING:** Indicates a situation in which serious injury or death could result if the warning is ignored.
 -  **CAUTION :** Indicates a situation in which bodily injury or damage to the vehicle could result if the caution is ignored.
- Do not modify the mud flap.
- Do not install the mud flap in any way other than described in the following instructions.
- If in any doubt, please ask your Mazda dealer to install the accessory in order to prevent errors in installation.
- If you have any questions about the use of the accessory, ask your Mazda dealer for proper advice before using it.
- Mazda and its suppliers are not responsible for injuries, accidents, and damage to persons and property that arise from the failure of the dealer or installer to follow these instructions.
- To ensure safety and reliability of the work, installation, removal and disposal work must be carried out by an Authorized Mazda Dealership.
- Be careful not to lose removed parts, and be sure that they are kept free from scratches, grease or other dirt.

PART NAME: MUD FLAP (REAR)
PART NUMBER: N121 V3 460F
VEHICLE: MX-5

NOTE

To the dealer

- Please turn over these instructions to the customer after installation.

To the customer

- Keep these instructions after installation. The instructions may be necessary for installing other optional parts or removal of this accessory.
- Should the vehicle or this accessory be resold, always leave these instructions with it for the next owner.

1. PARTS

Parts list

NOTE

- Before installation, verify that the kit includes all the following parts and that they are free of dirt, scratches, or damage.

部 品	名 称	数 量	部 品	名 称	数 量	部 品	名 称	数 量
	Mud flap (Front) (LH,RH)	1ea.		Bolt (9YA01 0502)	4		Clip nut (B092 51 861)	4
	Installation instructions	1						

Installation view

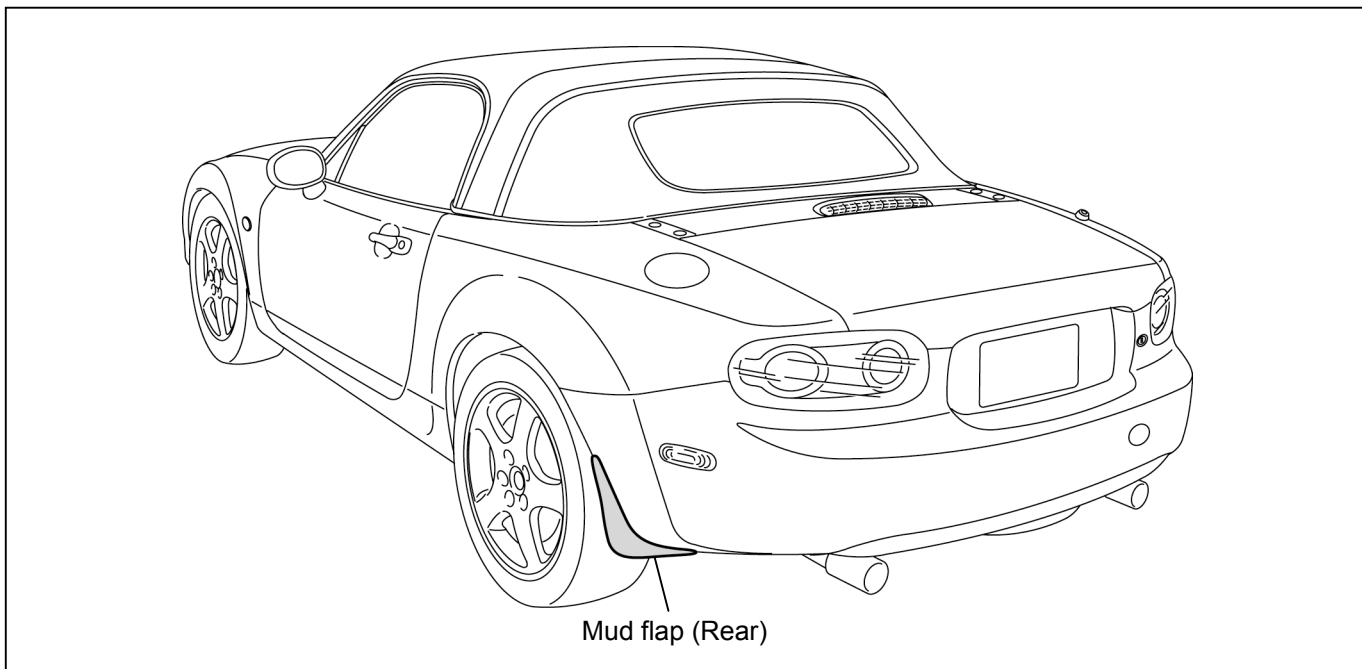

2. REQUIRED TOOLS

Screwdriver (Phillips)
Isopropyl alcohol (IPA)

Torque wrench

Nipper

Jack

Soft clean cloth

3. BEFORE INSTALLATION

⚠ CAUTION

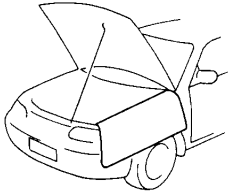
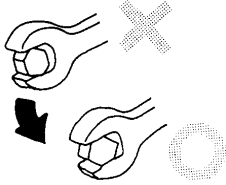
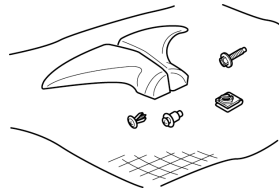
<p>Be sure to cover the vehicle body With protectors or mats to prevent stains, scratches and damage when removing/installing the vehicle parts</p>	<p>Use the most appropriate (size, use) tool for each task and perform the may be damaged.</p>	<p>Place the removed parts and kit accessories on a protective sheet to prevent scratches.</p>
		

NOTE

- Refer to the Workshop Manual for removal and installation of vehicle parts. Not following the procedures for removal/installation in the Workshop Manual could result in an accident or vehicle malfunction.

4. MUD FLAP (REAR) INSTALLATION

⚠ WARNING

- Park the vehicle on a flat, level surface, set the selector lever to P (AT vehicles) or the shift lever to 1st or R (MT vehicles), apply the parking brake and block the wheels so that the vehicle does not move during installation.

⚠ CAUTION

- Always use a torque wrench when tightening bolts and tighten to the specified torque. If tightened outside the specified torque, it could result in poor fit, part damage, or other damage.
- The mud flap (Rear) is made of hard plastic. Handle it with care, as it may be deformed or discolored if it contacts solvents such as paint thinner or comes close to flame.

NOTE

- The figure shows the left side, however, perform the same procedure for the right side.

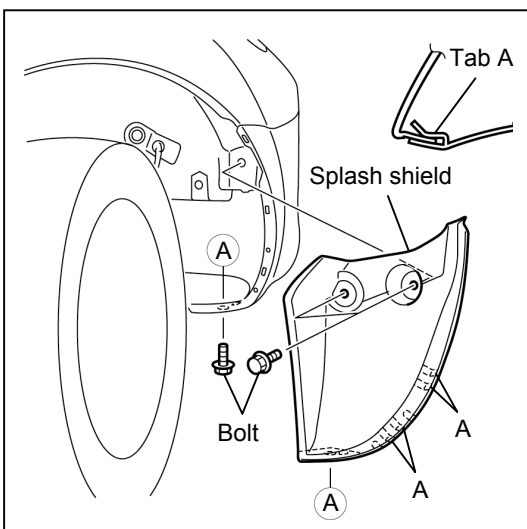

- 1 . Remove the splash shield installation bolts (3).
- 2 . Pull the splash shield inward and disengage the tabs (4 locations), and then remove the splash shield.

⚠ CAUTION

- The removed bolt (3) are to be reused. Be careful not to damage or lose them.

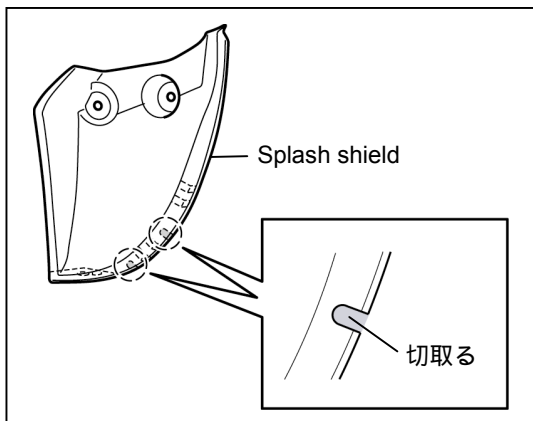

3 . Cut off the two locations on the splash shield shown in the figure using nippers.

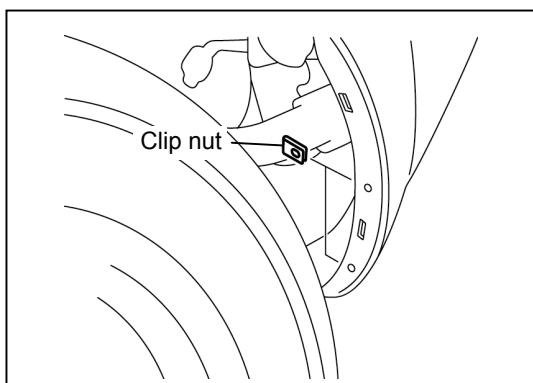

4 . Align the rear bumper holes, and install the kit clip nuts (2).

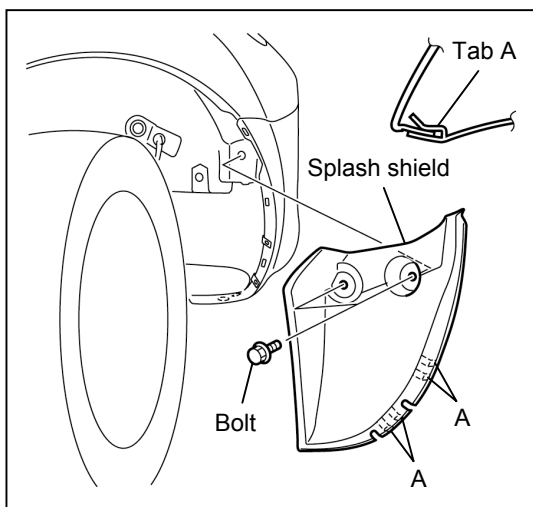

5 . Place the splash shield back in its original position and install the bolts (2).

⚠ **CAUTION**

- The mud flap (rear) is to be tightened together with the lower bolt (1) of the rear bumper. Do not install the bolt at this point in the procedure.

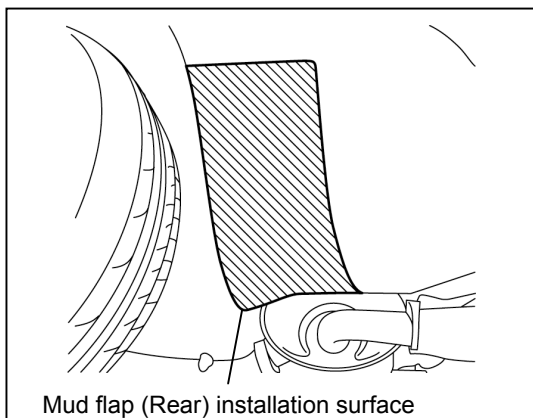

6 . Use a soft cloth dampened with IPA (isopropyl alcohol) to clean the surface of the vehicle where the mud flap (Rear) is to be installed.

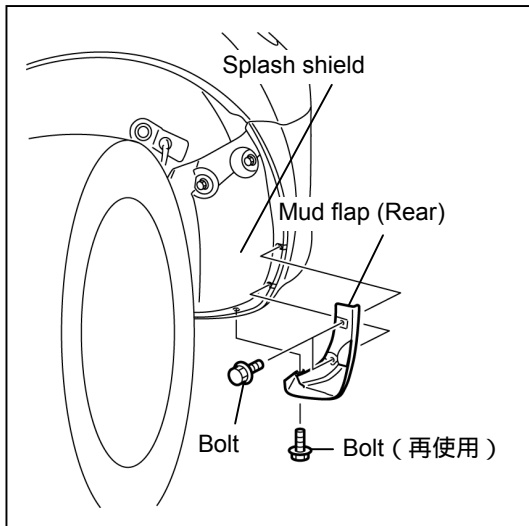

- 7 . Align the mud flap (rear) with the rear bumper and splash shield installation holes.
- 8 . Temporarily tighten the kit bolts (2) and the re-useable lower rear bumper bolt (1).
- 9 . Install the mud flap (rear) in the order of top, middle, and bottom while pressing the mud flap (rear) against the rear bumper.

Tightening torque

Bolt : 1.4 - 1.5 N·m { 14.0 - 15.0 kgf·cm · 12.4 - 13.2 in·lbf }

⚠ CAUTION

- Make sure the bolt is tightened securely. Make sure to tighten to the specified torque. If tightened outside the specified torque, the mud flap (rear) could be damaged or fall off.

5. CONFIRMATION AFTER INSTALLATION

1 . Be sure that there are no excessive gaps.

- If there are any gaps, loosen all the bolts and then retighten them in the order of top, middle, and bottom while pressing the mud flap (rear) against the vehicle.

2 . Be sure that all bolts are securely tightened.

**INSTALLATION
INSPECTION
SHEET**

MX-5

MUD FLAP (REAR)

N121 V3 460F

Inspection after installation

- Inspect the installed / reinstalled parts for the following items.

Inspection Parts	Check Item ()			
	Clearance/Fit	Scratches / Dirt	Installation / Engagement	ボルトのしめ具合
Mud flap (Rear)				
Splash shield				

Installation inspection sheet for mud flap (Rear)

Date				
VIN.				
Approved		Checked		Person in charge

The term of validity for this sheet: 3 months