

GENUINE Foot lamp & illumination

INSTALLATION INSTRUCTIONS

Thank you for purchasing a genuine Mazda accessory.

Before removal and installation, be sure to thoroughly read these instructions.

Please read the contents of this booklet in order to properly install and use the foot lamp & illumination. Your safety depends on it.

Keep these instructions with your vehicle records for future reference.



- There are several **⚠WARNING** and **⚠CAUTION** sections in this booklet concerning safety when installing or removing the foot lamp & illumination. Always read and follow them in order to prevent injuries, accidents, and possible damage to the vehicle.

⚠ WARNING: Indicates a situation in which serious injury or death could result if the warning is ignored.

⚠ CAUTION : Indicates a situation in which bodily injury or damage to the vehicle could result if the caution is ignored.

- Do not modify the foot lamp & illumination.
- Do not install the foot lamp & illumination in any way other than described in the following instructions.
- If in any doubt, please ask your Mazda dealer to install the accessory in order to prevent errors in installation.
- If you have any questions about the use of the accessory, ask your Mazda dealer for proper advice before using it.
- Mazda and its suppliers are not responsible for injuries, accidents, and damage to persons and property that arise from the failure of the dealer or installer to follow these instructions.
- To ensure safety and reliability of the work, installation, removal and disposal work must be carried out by an Authorized Mazda Dealership.
- Be careful not to lose removed parts, and be sure that they are kept free from scratches, grease or other dirt.

PART NAME: Foot lamp & illumination
PART NUMBER: NH18 V7 050
VEHICLE: MAZDA MX-5

NOTE

To the dealer

- Please turn over these instructions to the customer after installation.

To the customer









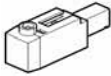

- Keep these instructions after installation. The instructions may be necessary for installing other optional parts or removal of this accessory.
- Should the vehicle or this accessory be resold, always leave these instructions with it for the next owner.

1. PARTS

Parts list

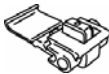
NOTE

- Before installation, verify that the kit includes all the following parts and that they are free of dirt, scratches, or damage.

Part	Part name	Qty	Part	Part name	Qty	Part	Part name	Qty
	Control unit	1		Main harness	1		★LED lamp (D651 V7 052)	2
	Bracket (ID: A P8143)	1		★Switch harness Switch label (E223 V7 055)	1ea.		Bolt	1
	Nut	1		Electro-tap	3		Tie wrap	9
	Double-sided adhesive tape	3		Cushioning tape	2		Installation instructions Installation inspection sheet Template	1ea.

★Indicates item can be purchased as a single unit.
Verify the part number before placing an order.

Installation view

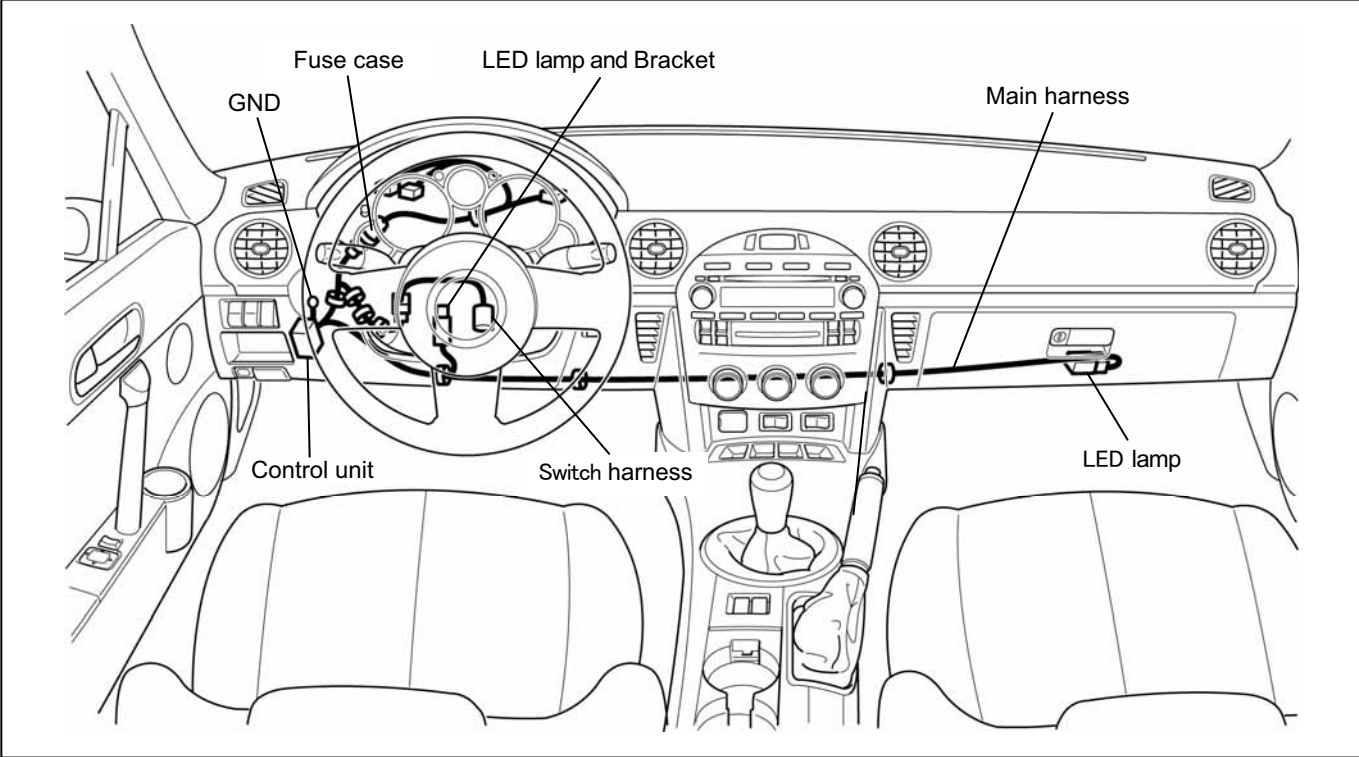

2. REQUIRED TOOLS





☆Screwdriver (Phillips) ☆Flathead screwdriver ☆Wrench ☆Torque wrench ☆Pliers ☆Nipper
 ☆Scissors ☆Cutter knife ☆Punch ☆Electric drill (ϕ 4mm, 8.5mm) ☆Hole saw (ϕ 20mm)
 ☆Electrical vinyl tape ☆Flathead screwdriver wrapped with protective tape
 ☆Fastener remover wrapped with protective tape ☆Mat ☆Soft clean cloth ☆Isopropyl alcohol (IPA)

3. BEFORE INSTALLATION

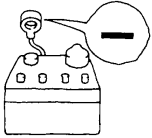

⚠ WARNING

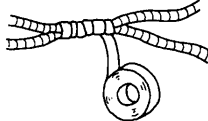
- Park the vehicle on a flat, level surface, set the selector lever to P (AT vehicles) or the shift lever to 1st or R (MT vehicles), apply the parking brake and block the wheels so that the vehicle does not move during installation.

⚠ WARNING

When the negative battery cable is connected during operation, it may cause electric shock or other personal injuries. Disconnect the negative battery cable before removal/installation.	Do not pull the harness with excessive force. Doing so can cause a breakage or a short-related accident, as well as an electrical short or fire.	Secure the harness with the band (part included) so it doesn't dangle. If not, it may cause a short, accident, or fire.	When connecting/disconnecting connectors, grasp the connectors, not the wires. Otherwise a short, an accident from poor contact or fire may occur.
			

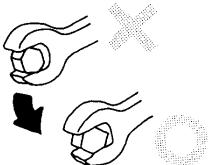
⚠ CAUTION

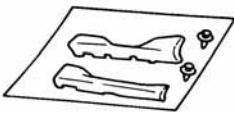
Using improper tools may cause damage and or broken parts. Use the correct tool for the job.	Wrap protective tape around screwdrivers and fastener remover tools to prevent scratching the vehicle.	Excessive length of tie wrap may interfere with other parts and cause damage. Cut unnecessary part up to about 5 mm {0.19 in} from the fixed point.	Place the removed parts and kit accessories on a protective sheet to prevent scratches.
			

⚠ CAUTION

- When the negative battery cable is removed, the clock, radio, trip meters and other memories will be erased. Before performing work, record the content of the memory.

NOTE

- Refer to the Workshop Manual for removal and installation of vehicle parts. Not following the procedures for removal/installation in the Workshop Manual could result in an accident or vehicle malfunction.

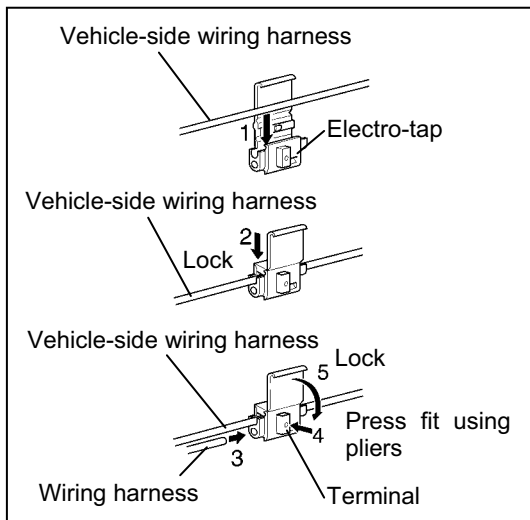

Branching connection using electro-tap

1. Pass the vehicle-side wiring harness through the electro-tap.
2. Fold the electro-tap in the direction of the arrow and lock it.

⚠ CAUTION

- Lock the electro-tap locking area firmly until a click sound is heard.

3. Insert the wiring harness into the electro-tap until it contacts the end.
4. Press fit the electro-tap terminal using pliers.
5. Fold the electro-tap in the direction of the arrow and lock it.

4. CONNECTION DIAGRAM

Figure shows connector viewed from harness side.

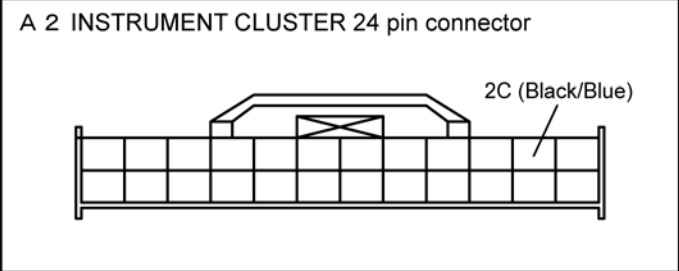
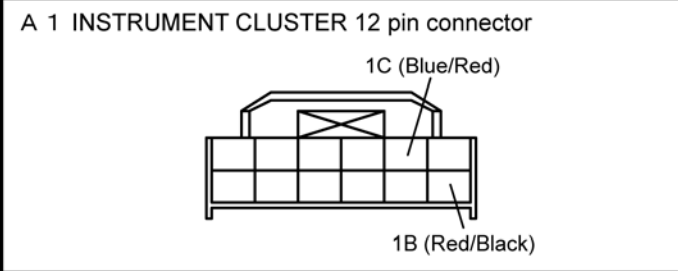
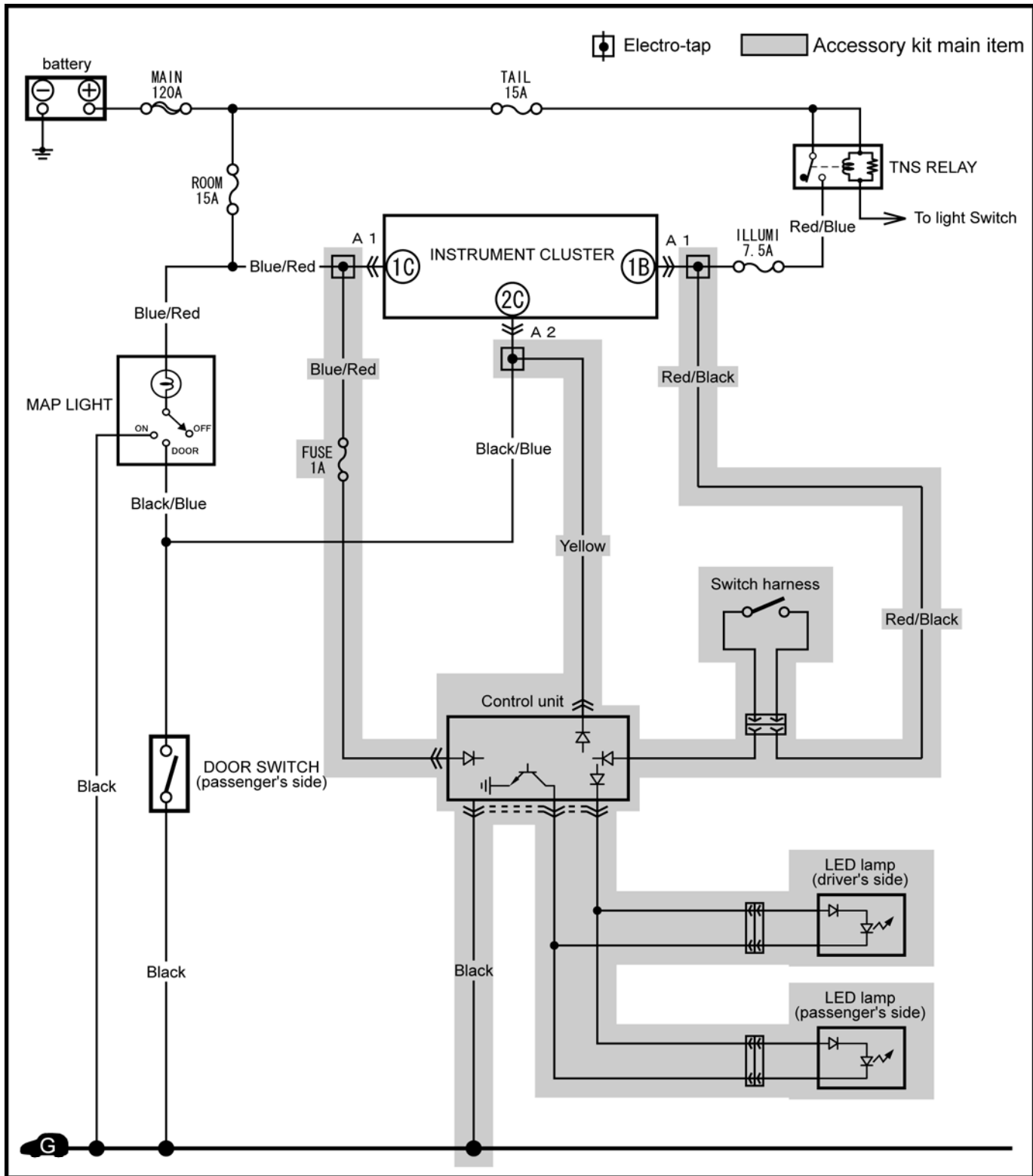

5. PART REMOVAL

⚠ CAUTION

- Be careful not to damage or lose any parts removed from the vehicle since they will be reused.

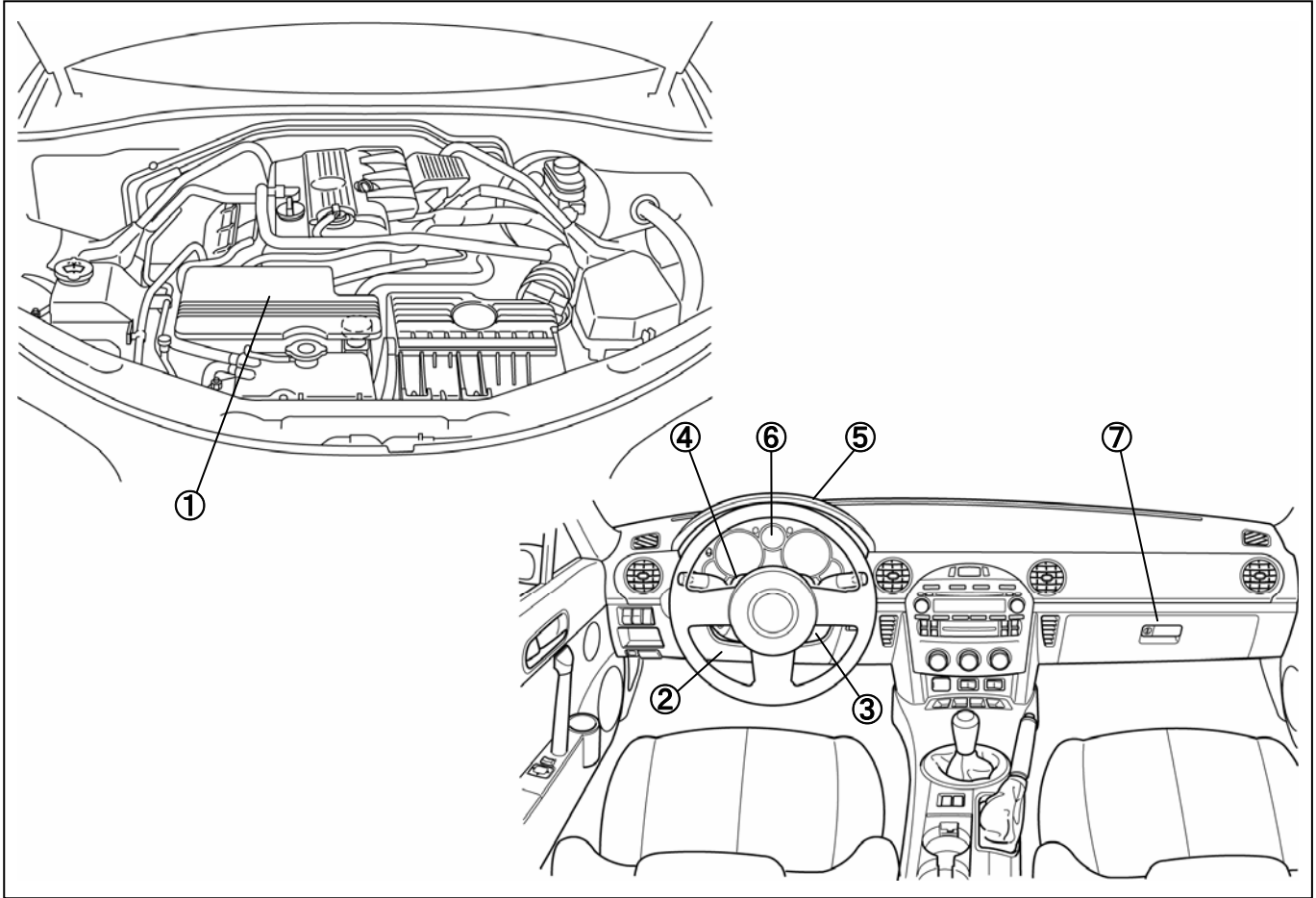

* Remove parts in the order of the numbers indicated as follows:

- | | |
|--|------------------------------|
| ① Negative battery cable disconnection | ⑤ Meter hood removal |
| ② Lower panel removal | ⑥ Instrument cluster removal |
| ③ Knee bolster removal | ⑦ Glove compartment removal |
| ④ Column cover (Upper/Lower) removal | |

① Negative battery cable disconnection

1. Set the selector lever to D range.
(AT vehicles only)
2. Disconnect the negative battery cable and wrap tape around it to insulate.

⚠ WARNING

- When the negative battery cable is connected during operation, it may cause electric shock or other personal injuries. Disconnect the negative battery cable before removal/installation.
- When removing/installing the parts, park the vehicle on level ground and apply the side brake securely. Be sure to turn the ignition switch off, otherwise the vehicle can move, causing personal injury or vehicle damage.

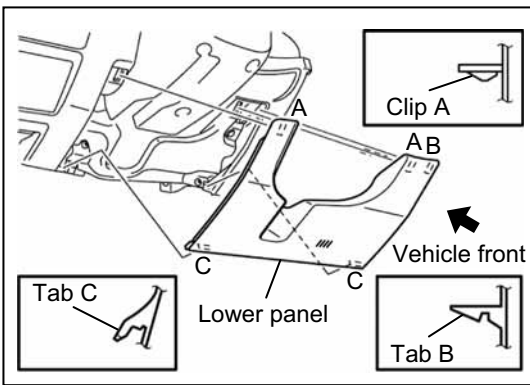

② Lower panel removal

1. Pull the top side of the lower panel outward, and then remove clips A (2 locations) and tab B (1 location).
2. Remove tabs C (2 locations), then remove the lower panel.

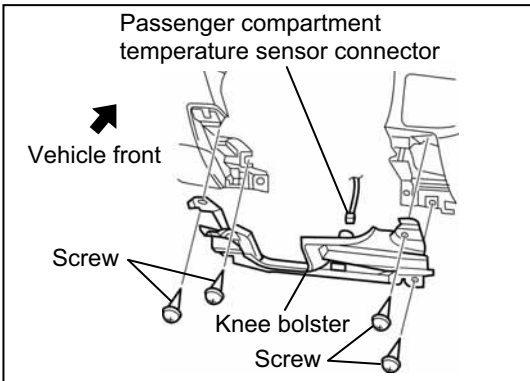

③ Knee bolster removal

1. Remove the screws (4 locations).
2. Disconnect the passenger compartment temperature sensor connector.
3. Remove the knee bolster.

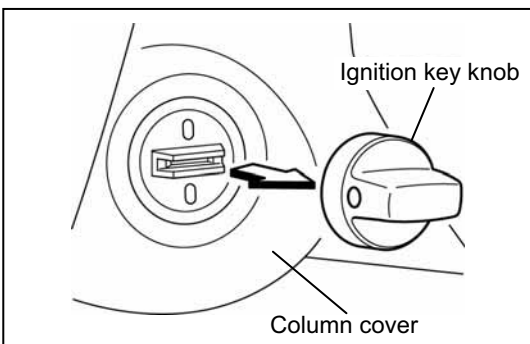

④ Column cover (Upper/Lower) removal

1. Remove the Ignition key knob.
(Vehicles with advanced keyless system only)

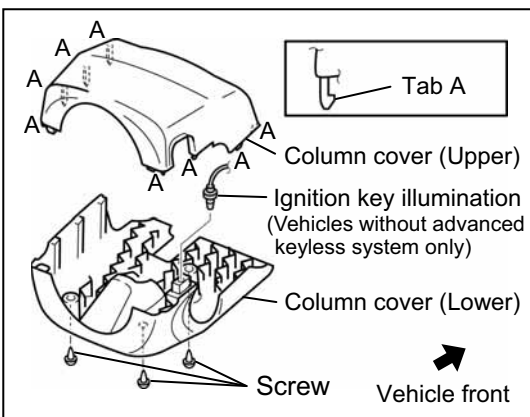

2. Remove the tabs A (8 locations), then remove the upper column cover.
3. Remove screws (3 locations), then remove the column cover (Lower).
4. Remove the ignition key illumination.
(Vehicles without advanced keyless system only)

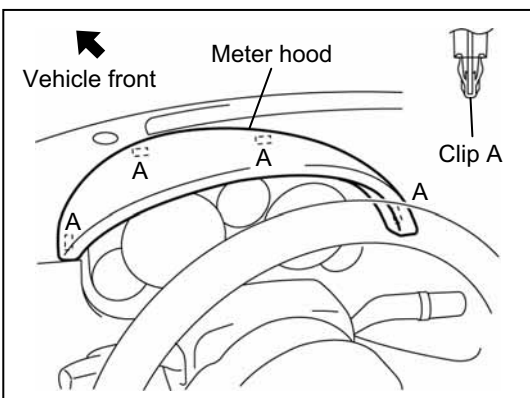

⑤ Meter hood removal

1. Pull the meter hood upward and detach clips A (4 locations).

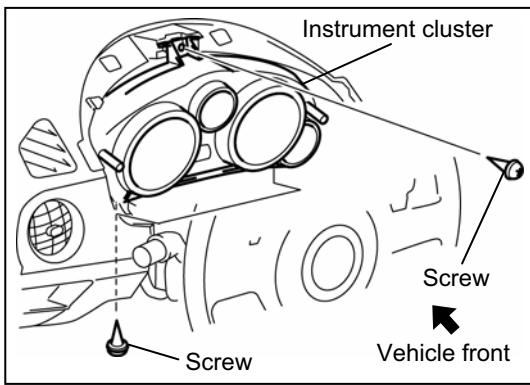

⑥ Instrument cluster removal

1. Remove the screws (3 locations).

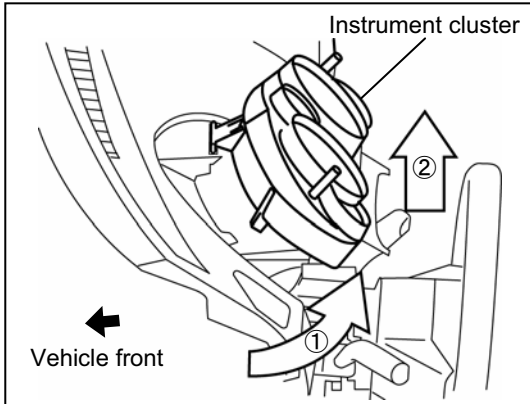

2. Rotate the instrument cluster in the direction of the arrow and remove the instrument cluster.

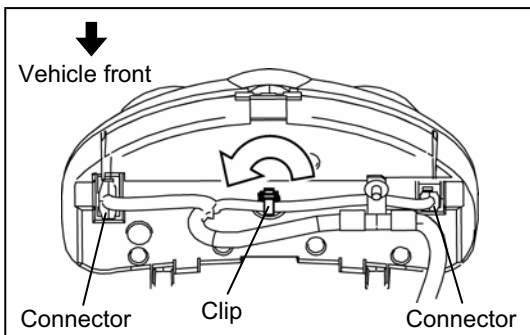

3. Disconnect the connectors (2 locations).

4. Detach the clip (1 location), and then remove the instrument cluster.

⚠ CAUTION

- Rotate the clip B 90°, then remove the clip B from the instrument cluster.

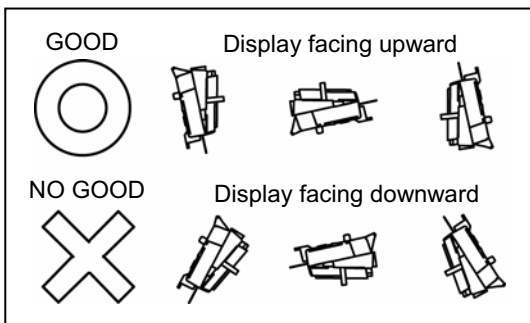

⚠ CAUTION

- The removed instrument cluster should be placed with the display side up to prevent grease from leaking from the meters.

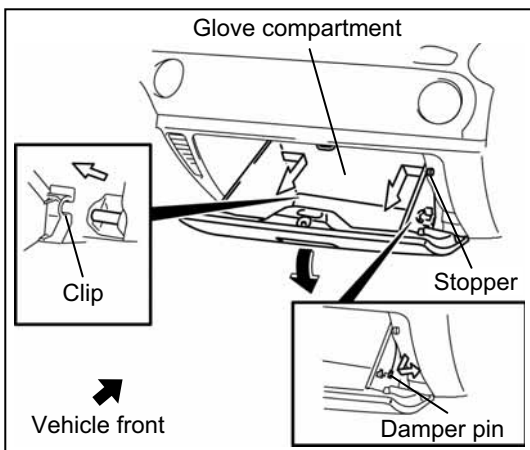

⑦ Glove compartment removal

1. Open the glove compartment lid and remove the damper pin.

2. Push the glove compartment lid inward and disengage the stoppers (2 locations).

3. Pull the glove compartment lid outward, detach the clips (2 locations), and then remove the glove compartment lid.

6. PREPARATIO FOR INSTALLATION

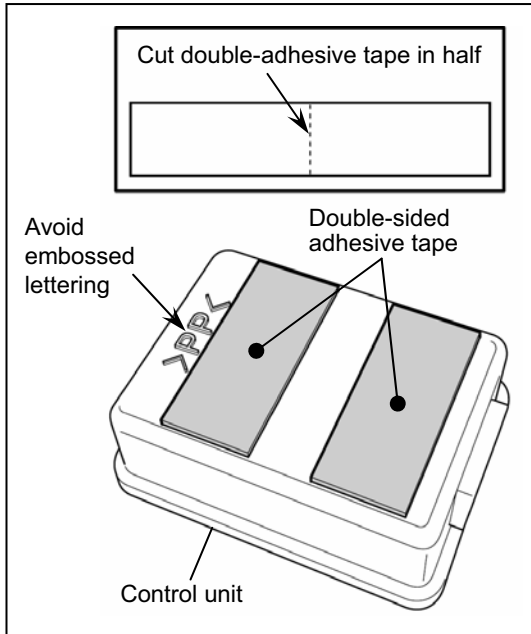

Control unit installation

1. Affix the double-sided adhesive tapes (2 locations) to the Control unit as shown in the figure.

⚠ CAUTION

- To ensure proper affixing, be sure to degrease the area where the double-sided adhesive tape is affixed.

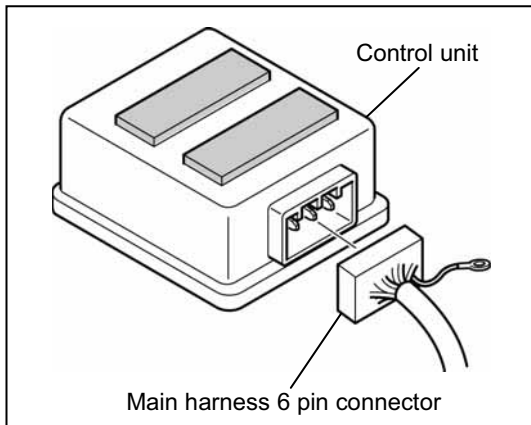

2. Connect the main harness 6 pin connector to the Control unit.

⚠ CAUTION

- Insert the connector firmly until a click sound is heard.

Switch harness installation

1. Drill an initial 4 mm diam. hole in the position shown in figure from the backside of the lower column cover.
2. Using a 20 mm diam. hole saw, saw an installation hole for the switch wiring harness from the front side of the lower column cover.
3. Process the notch at the position shown in the figure on the left.

⚠ WARNING

- Be careful when handling drills and other sharp objects. If not handled properly, it could result in serious injury.

⚠ CAUTION

- Make sure to remove burrs from both the surfaces so that they are flat and smooth.

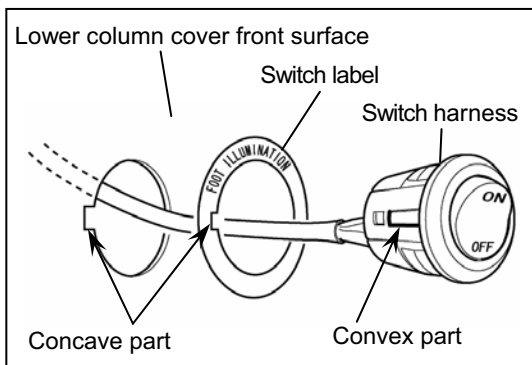
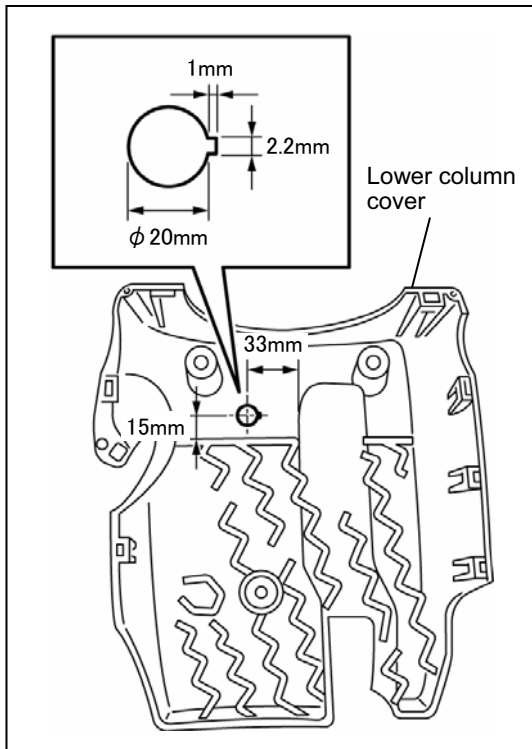

4. Remove the paper backing from the switch label and adhere the label to the front side of the lower column cover.
5. Pass the switch wiring harness through the backside of the lower column cover and install it.

LED lamp (driver's side) installation

1. Install the LED lamp to the bracket.

⚠ CAUTION

- Verify that the bracket installation orientation is correct. Once the bracket is installed it cannot be removed.
- Firmly insert the bracket until the projection reaches the bracket hole.

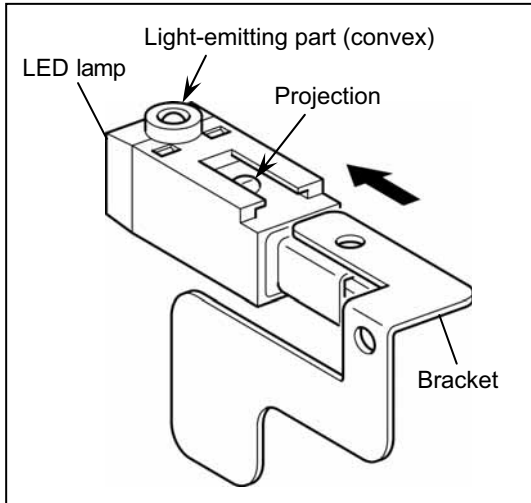

2. Cut one piece of the double-sided adhesive tape to the dimensions shown in the figure and adhere it to the bracket.

⚠ CAUTION

- To ensure proper affixing, be sure to degrease the area where the double-sided adhesive tape is affixed.

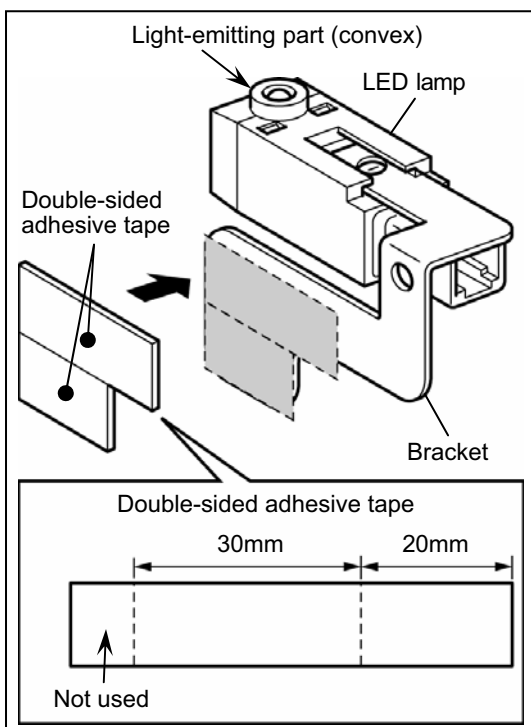

3. Cut out the templates with scissors along the cut lines.

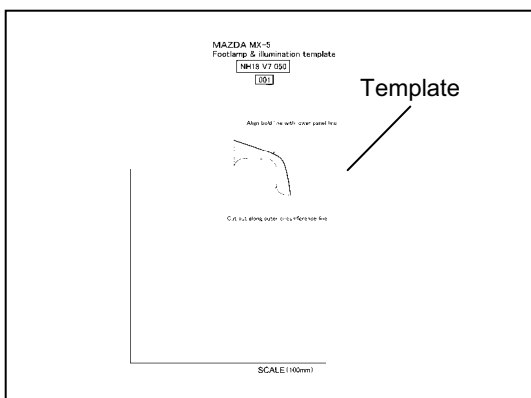

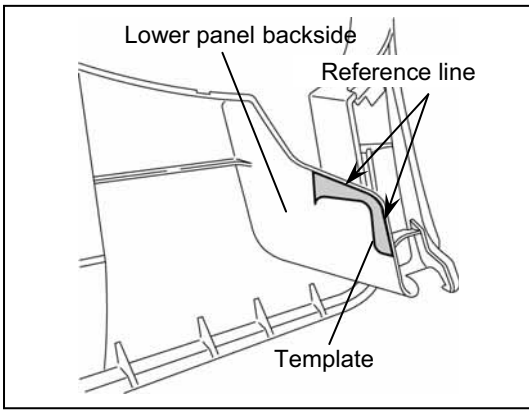

- Align the template reference line as shown in the figure and affix it with masking tape.

CAUTION

- Affix the template making sure there are no wrinkles or misalignment.

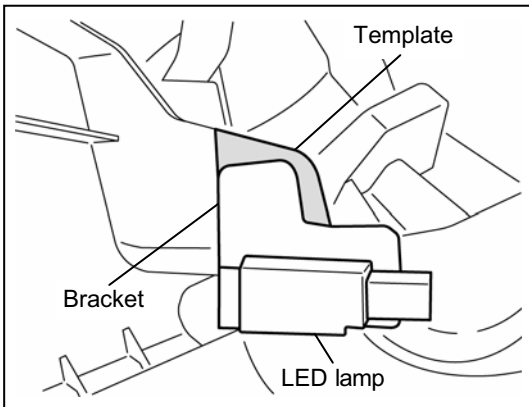

- Remove the paper backing from the double-sided adhesive tape of the bracket, align the bracket with the template affixed to the backside of the lower panel, and install the bracket.

CAUTION

- The adhesive strength of the double-sided adhesive tape will be weakened if it is removed once it has been adhered. Make sure the adhesion position is correct before the tape is adhered.
- To ensure proper affixing, be sure to degrease the area where the double-sided adhesive tape is affixed.

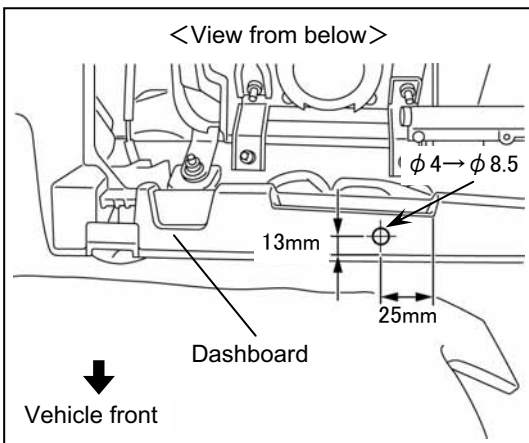

LED lamp (passenger's side) drilling

- Drill an initial 4 mm diam. hole in the position shown in the figure from the underside of the instrument panel, and then expand the hole to an 8.5 mm diameter.

WARNING

- Be careful when handling drills and other sharp objects. If not handled properly, it could result in serious injury.

CAUTION

- Make sure to remove burrs from both the surfaces so that they are flat and smooth.

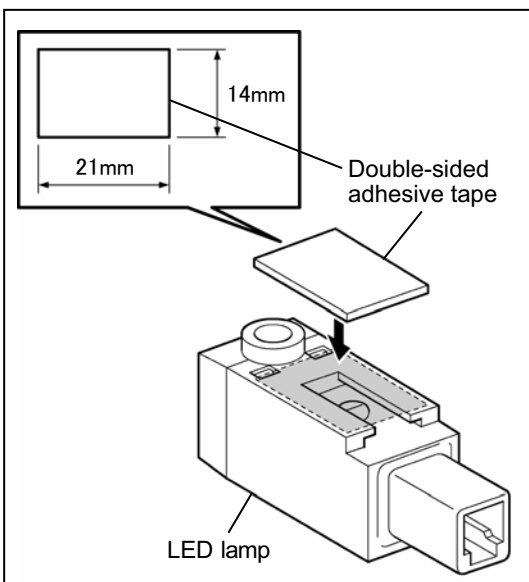

- Cut one piece of the double-adhesive tape to the dimensions shown in the figure on the left, and adhere it to the LED lamp.

CAUTION

- To ensure proper affixing, be sure to degrease the area where the double-sided adhesive tape is affixed.

7. INSTALLATION AND WIRING

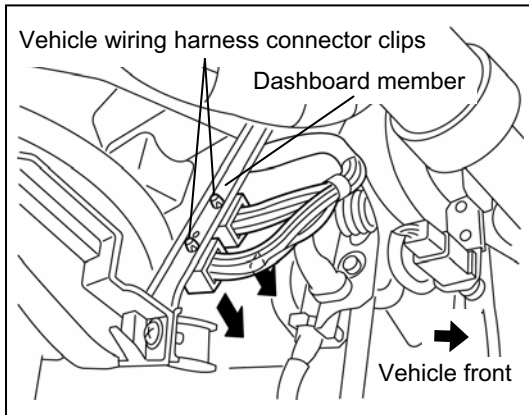

1. Remove the vehicle wiring harness connector from the dashboard member in two locations.

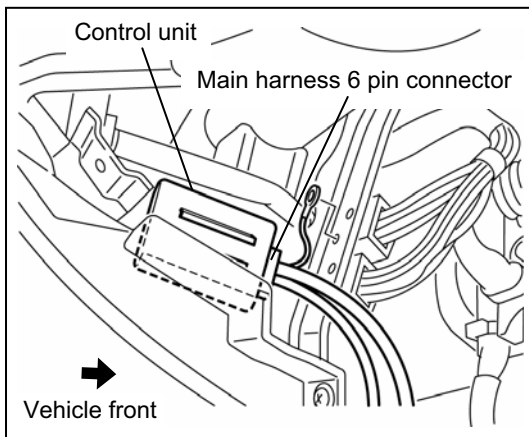

2. Adhere the control unit to the vertical surface of the dashboard on the left side of the driver's seat.

⚠ CAUTION

- Make sure to install the control unit connector part so that it is pointed towards the front of the vehicle.
- To ensure proper affixing, be sure to degrease the area where the double-sided adhesive tape is affixed.

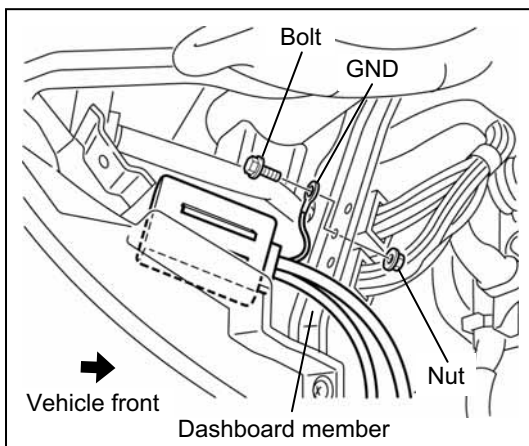

3. Secure the main wiring harness ground wire (black) using the bolt (1) and nut (1) on the dashboard member.

• Bolt tightening torque:

6.9 – 9.8 N·m {70.4 – 100.0 kgf·cm · 61.1 – 86.7 in·lbf }

4. Install the vehicle wiring harness connector to the dashboard member in the two locations.

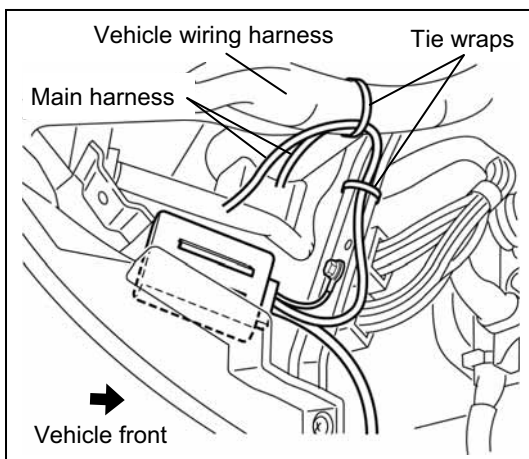

5. Secure the main harness to the dashboard member with tie wrap (1 location).
6. Secure the main harness to the vehicle wiring harness with tie wrap (1 location).

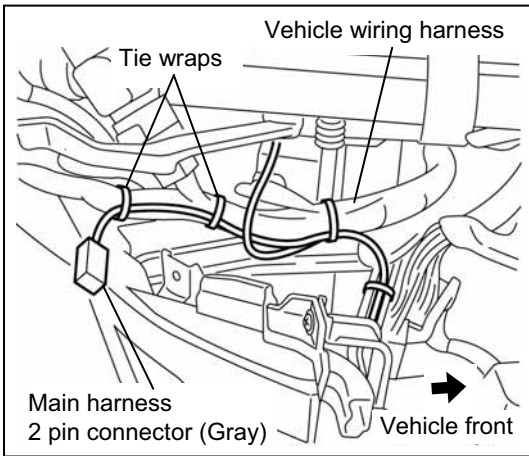

7. Route the main wiring harness 2-terminal connector (grey) alongside the vehicle wiring harness and secure it with tie wraps in two locations.

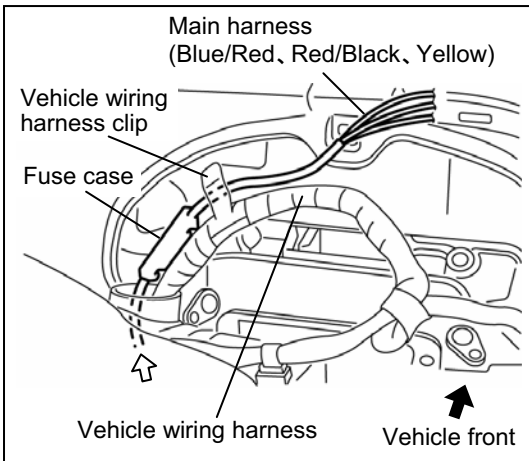

8. Route the main wiring harness (blue/red wire, yellow/black wire, yellow wire) alongside the vehicle wiring harness, and then route it behind the instrument cluster.

CAUTION

- When routing the main wiring harness (blue/red wire, red/blue wire, black/blue wire), route it along the backside of the vehicle wiring harness.

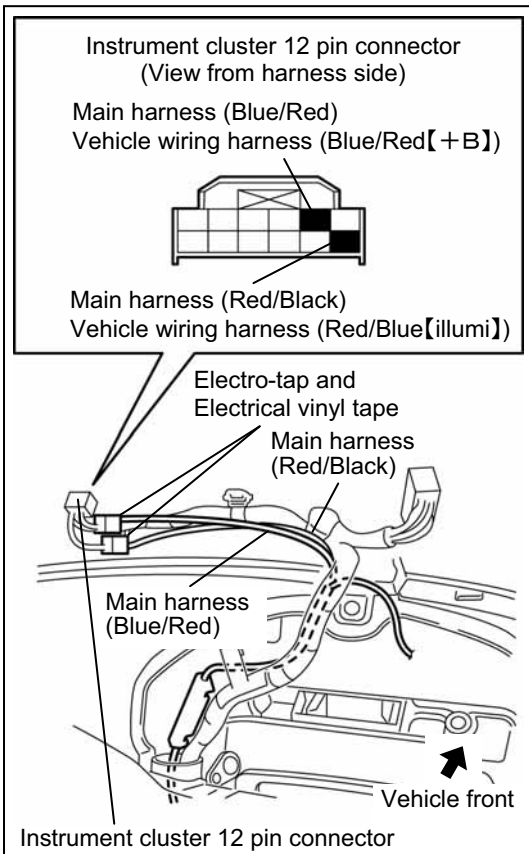

9. Branch-connect each of the main wiring harnesses (blue/red wire, red/black wire) to the instrument cluster 12-pin connector (blue/red (+B), red/blue (illumi)) with electro-taps, and wrap the electro-taps with electrical tape.

CAUTION

- Firmly connect the electro-taps to the indicated signal lines. If they are not connected correctly, it could result in a system or vehicle malfunction.

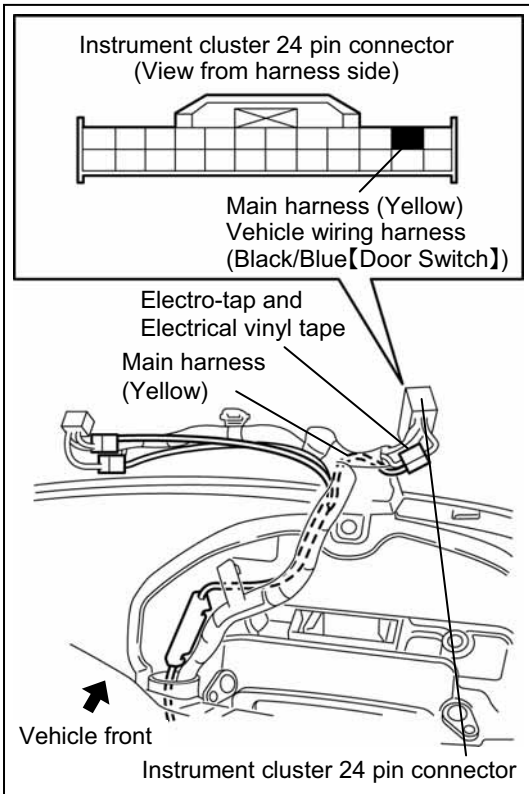

10. Branch-connect the main wiring harness (yellow wire) to the instrument cluster 24-pin connector (black/blue (door switch)) with an electro-tap, and wrap the electro-tap with electrical tape.

CAUTION

- Firmly connect the electro-tap to the indicated signal line. If it is not connected correctly, it could result in a system or vehicle malfunction.

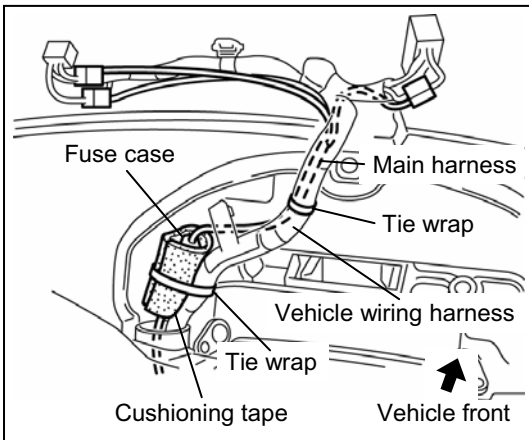

11. Secure the main harness to the vehicle wiring harness with tie wrap (1 location).
12. Wrap the main wiring harness fuse with a piece of cushioning tape.
13. Secure the fuse wrapped with cushioning tape together with the vehicle wiring harness using a tie wrap in one location.

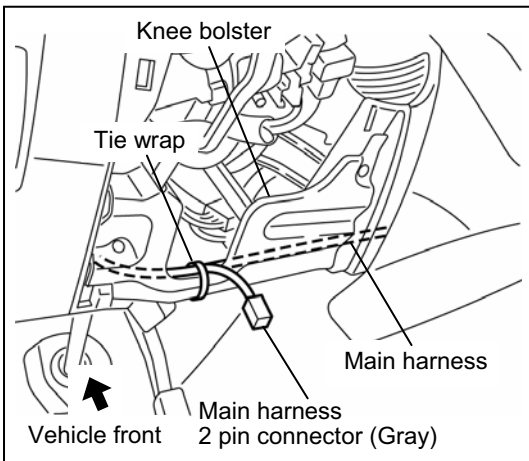

14. Connect the passenger compartment temperature sensor connector, then install the knee bolster.
15. Secure the main harness to the knee bolster with tie wrap (1 location).

CAUTION

- When routing the main wiring harness, do not allow it to interfere with the passenger compartment temperature sensor.

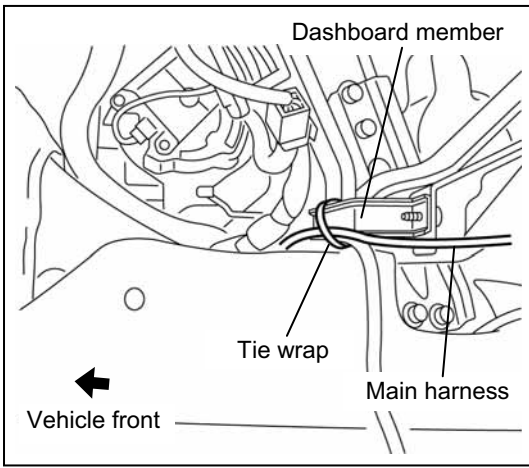

16. Secure the main harness to the dashboard member with tie wrap (1 location).

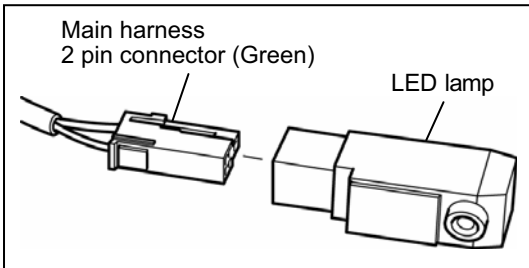

17. Shift to the front passenger side and connect the main wiring harness 2-terminal connector (green) to the LED lamp (front passenger side).

CAUTION

- Firmly insert the connector until a click sound is heard.

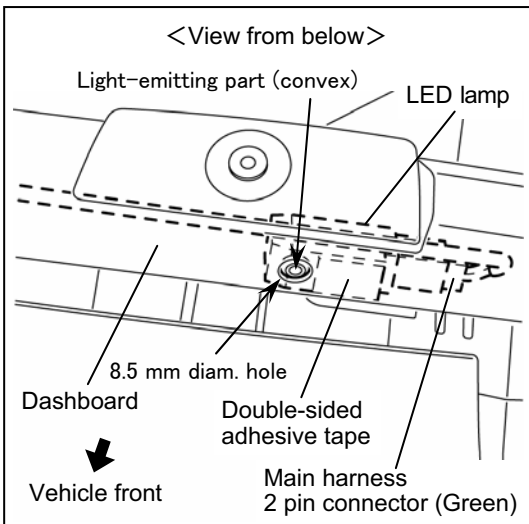

18. Remove the paper backing of the double-sided adhesive tape, insert the light-emitting part (convex) of the LED lamp through the hole (8.5 mm diam.) in the instrument panel, and install the LED lamp.

CAUTION

- The adhesive strength of the double-sided adhesive tape will be weakened if it is removed once it has been adhered. Make sure the adhesion position is correct before the tape is adhered.
- When installing the LED lamp to the instrument panel, make sure the connection part of the connector is pointed towards the vehicle front. Also, when routing the main wiring harness, always pass it between the instrument panel and LED lamp (front passenger side)
- To ensure proper affixing, be sure to degrease the area where the double-sided adhesive tape is affixed.

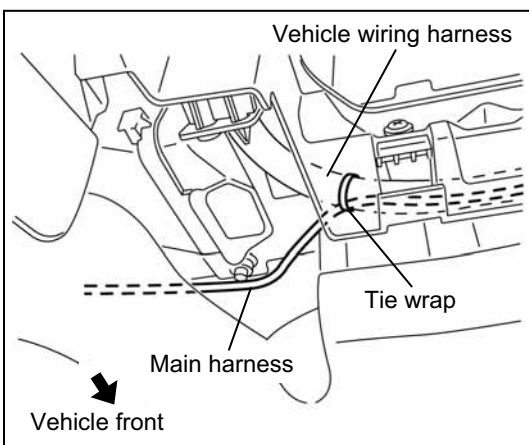

19. Secure the main harness to the vehicle wiring harness with tie wrap (1 location).

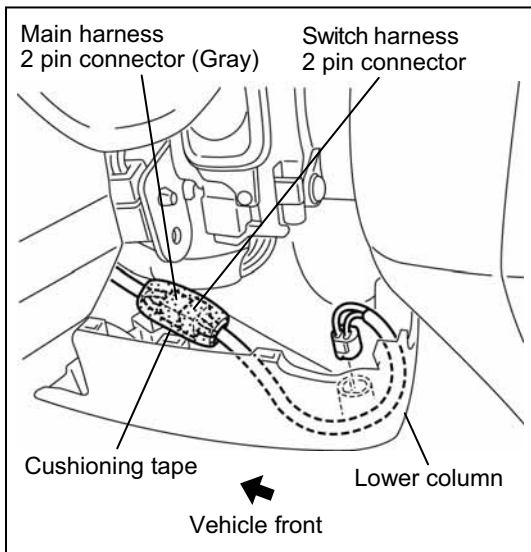

20. Connect the main wiring harness 2-terminal connector (grey) to the switch wiring harness 2-terminal connector installed to the backside of the lower column cover.

⚠ CAUTION

- Firmly insert the connector until a click sound is heard.

21. Temporarily install the lower column cover.

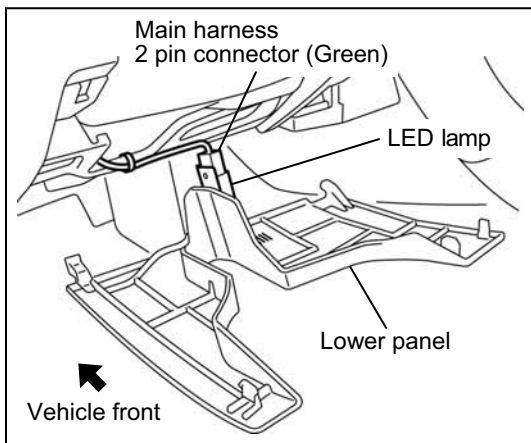

22. Connect the main wiring harness 2-terminal connector (green) to the LED lamp (driver' side) installed to the backside of the lower panel.

⚠ CAUTION

- Firmly insert the connector until a click sound is heard.

23. Temporarily install the lower panel.

8. OPERATION CHECK

1. Operation check on vehicle side

1. Connect the negative battery cable.
2. Verify that the operation of the instruments, map light, and power door locks (lock/unlock) is normal.

◆ Operation check precautions

⚠ WARNING

- Before starting the engine, make sure nobody is in front or back of the vehicle, or in the engine compartment. If the vehicle were to move suddenly it could cause a serious accident.
- Do not start the engine in a place such as a garage or other location with poor air ventilation. Otherwise, poisoning or asphyxiation could result from accumulation of exhaust gas.

⚠ CAUTION

- Disconnecting the battery causes the DSC indicator light to become inoperable. (At this point, the DSC OFF indicator light flashes and the TCS/DSC indicator light is illuminated.) To restore the DSC to an operable condition, perform the following procedures:
 1. Turn the ignition switch to the ON position.
 2. Turn the steering wheel completely to the right and then completely to the left.
 3. Verify that the DSC OFF indicator light goes out.
 4. Turn the ignition switch off and then turn it to the ON position again.
 5. Verify that the TCS/DSC indicator light goes out.
- ※ If the TCS/DSC or DSC OFF indicator lights do not go out after turning the ignition switch to the ON position, consult your Mazda dealer.

2. LED lamp operation verification

1. Turn on the FOOT ILLUMINATION switch on the lower panel.
2. Set the vehicle map light switch to the center DOOR position.
3. Verify that the LED lamp illuminates when a door is opened.
4. With the doors are closed, verify that the LED lamp turns off simultaneously with the vehicle map light.
5. With the door closed (map light off), verify that the LED lamp illuminates in a dimmed state when the vehicle headlight switch is turned to “●” or “☰D”
6. While under the condition in Step 5, turn off the FOOT ILLUMINATION switch and verify that foot lamp turns off. After verifying, turn the FOOT ILLUMINATION switch back on
7. Unlock the doors using the transmitter and verify that vehicle map light and the LED lamp illuminate simultaneously.

INSTALLATION INSPECTION SHEET

MAZDA MX-5

Foot lamp &
illumination

NH18 V7 050

A. Vehicle parts reinstallation

- Install removed vehicle parts in the reverse order of "VEHICLE PARTS REMOVAL".

⚠ CAUTION

- Make sure that the vehicle parts are clean before reinstalling. Clean any dirty parts.
- Verify that the connectors are securely connected.

Check

--

B. Inspection after installation

- Inspect the installed / reinstalled parts for the following items.

Inspection Parts	Inspection Items (O)			
	Clearance/Fit	Scratches/ Dirt/ Harness interference	Installation/ Tightening/ Engagement	Operation check
LED lamp	○	○	○	○
Glove compartment	○	○	○	
Instrument cluster	○	○	○	○
Meter hood	○	○	○	
Column cover (Upper/Lower)	○	○	○	○
Knee bolster	○	○	○	○
Lower panel	○	○	○	
Battery cable	○	○	○	
DSC indicator light				○

C. Important check items

- Inspect the installed / reinstalled parts for the following items.

No.	Items	Check
1	After installing the foot lamp and reinstalling the removed parts, operate the accelerator, brake (and clutch) pedals and steering wheel to verify that there is no interference with the foot lamp. (Check no interference by moving each part.)	
2	Verify that the harness does not interfere with the accelerator, brake (and clutch) pedals and steering wheel. (Check no interference by moving the harness with hand and by moving each unit.)	

Installation inspection sheet for foot lamp & illumination

Date				
VIN.				
Approved		Checked		Person in charge

MAZDA MX-5
Footlamp & illumination template

NH18 V7 050

001

Align bold line with lower panel line

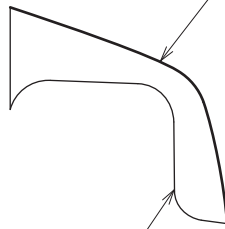

Cut out along outer circumference line

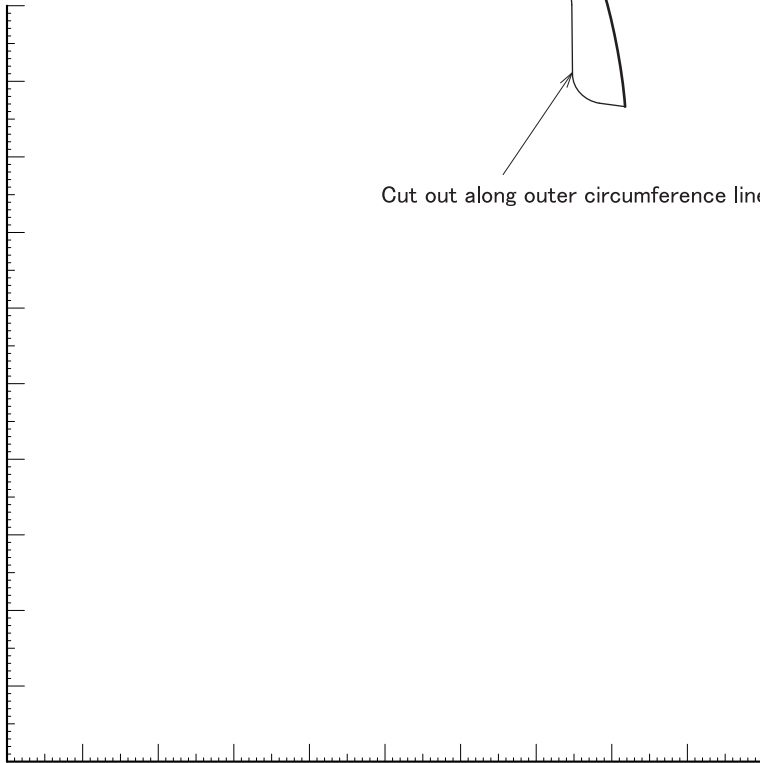

SCALE (100mm)

INSTALLATION INSPECTION SHEET

MAZDA MX-5

Foot lamp &
illumination

NH18 V7 050

A. Vehicle parts reinstallation

- Install removed vehicle parts in the reverse order of "VEHICLE PARTS REMOVAL".

⚠ CAUTION

- Make sure that the vehicle parts are clean before reinstalling. Clean any dirty parts.
- Verify that the connectors are securely connected.

Check

--

B. Inspection after installation

- Inspect the installed / reinstalled parts for the following items.

Inspection Parts	Inspection Items (O)			
	Clearance/Fit	Scratches/ Dirt/ Harness interference	Installation/ Tightening/ Engagement	Operation check
LED lamp	○	○	○	○
Glove compartment	○	○	○	
Instrument cluster	○	○	○	○
Meter hood	○	○	○	
Column cover (Upper/Lower)	○	○	○	○
Knee bolster	○	○	○	○
Lower panel	○	○	○	
Battery cable	○	○	○	
DSC indicator light				○

C. Important check items

- Inspect the installed / reinstalled parts for the following items.

No.	Items	Check
1	After installing the foot lamp and reinstalling the removed parts, operate the accelerator, brake (and clutch) pedals and steering wheel to verify that there is no interference with the foot lamp. (Check no interference by moving each part.)	
2	Verify that the harness does not interfere with the accelerator, brake (and clutch) pedals and steering wheel. (Check no interference by moving the harness with hand and by moving each unit.)	

Installation inspection sheet for foot lamp & illumination

Date				
VIN.				
Approved		Checked		Person in charge

The term of validity for this sheet: 12 months